

M Series Pressure Regulators

SUMMARY

| | |
|---|----|
| Introduction | 1 |
| P.E.D. Categories and Fluid Group | 2 |
| Characteristics | 2 |
| Labelling | 2 |
| Overpressure Protection | 3 |
| Transport and Handling | 3 |
| Atex Requirements | 3 |
| Slam-Shut Controller | 3 |
| Dimensions and Weights | 4 |
| Operation | 5 |
| Installation | 6 |
| Startup | 7 |
| Adjustment | 8 |
| Shutdown | 8 |
| Periodical Checks | 8 |
| Maintenance | 8 |
| Spare Parts | 9 |
| Troubleshooting | 10 |
| Parts List | 10 |
| Schematic Assemblies | 11 |

INTRODUCTION

Scope of Manual

This manual provides instructions for installation, startup, maintenance and spare parts ordering for the M series spring loaded regulators.

Product Description

The M series regulators are fail open, differential strength, spring loaded with counterbalanced shutter. They can be provided with slam-shut controller for minimum pressure, maximum pressure or minimum and maximum downstream pressure.

The regulators of the M series due to their operating specifications are mainly used in those system where sudden capacity variations are required, or else, where the cut-off of the gas distribution is controlled by solenoid valve, such as for the feeding of burners.

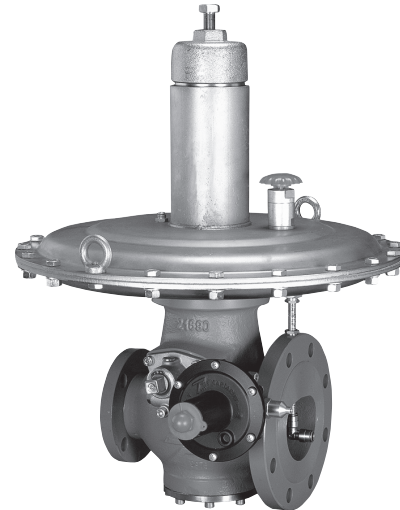

Figure 1. Regulator Type MBN

This product has been designed to be used with fuel gases of 1st and 2nd family according to EN 437, and with other non aggressive and non fuel gases. For any other gases, other than natural gas, please contact your local sales agent.

The following versions are available:

MN • MF: Regulator (pressure accessories)

MBN • MBF: Regulator with slam-shut (safety accessories)

MBN-M • MBF-M: Monitor with slam-shut (safety accessories)

MN, MF, MBN and MBF series with SR silencer are also available.

The standard gas pressure devices (regulators and safety shut-off devices) are those used in the assemblies dealt with into EN 12186 and EN 12279 and their use has to be under the provisions into ENs 12186 & 12279.

In the pressure regulators manufactured by Emerson Process Management shall be used additional pressure accessories (e.g. slam-shut controller) manufactured and labeled by Emerson Process Management.

Emerson Process Management will be not responsible for any possible inefficiency due to installation of not own production additional pressure accessories (e.g. slam-shut controller).

When pressure containing parts of possible built-in safety shut-off device (SSD) valve and pilot have different maximum allowable pressures, the SSD is differential strength type.

Type M

P.E.D. CATEGORIES AND FLUID GROUP

Fail open stand-alone M series regulators cannot be used as a safety accessory according PED 97/23/EC to protect downstream pressure equipment.

According to EN 14382, only in integral strength type and Class A configuration (when both over and under pressure protections are set up), the possible built-in safety shut-off device can be classified like a safety accessory according to PED.

The minimum PS between SSD valve and slam-shut controller shall be the PS of the safety accessory to comply the provisions of EN 14382 about integral strength type.

Downstream equipments, protected by possible built-in safety shut-off device (in its Class A and integral strength configuration) of this product, shall have technical features such as to be category per table below according Directive 97/23/EC "PED".

Table 1. M Series Regulators P.E.D. Category

| PRODUCT SIZE | CATEGORY | FLUID GROUP |
|--------------------------|----------|-------------|
| DN 25 | SEP | 1 |
| DN 40 TO DN 50 | I | |
| DN 65 TO DN 100 | II | |
| ALL SIZES WITH SLAM-SHUT | IV | |

The regulator size DN 25 and possible built-in pressure accessories (e.g. slam-shut controller OS/66) installed in all the available sizes of M series regulators, are conform to Pressure Equipment Directive (PED) 97/23/EC Article 3 section 3 and were designed and manufactured in accordance with sound engineering practice (SEP).

Per Article 3 section 3, these "SEP" products must not bear the CE marking.

CHARACTERISTICS

Body Sizes and End Connection Styles

MN • MBN • MBN-M (widened outlet)

DN 25x65, 40x80, 50x100, 65x100, 80x150, 100x200
PN 16, ANSI 150

MF • MBF • MBF-M (Same Size Inlet/Outlet)

DN 25, 40, 50, 65, 80, 100
PN 16, ANSI 150



WARNING

The pressure/temperature limits indicated in this instruction manual or any applicable standard or code limitation should not be exceeded.

Maximum Operating Inlet Pressure

MN • MBN • MBN-M DN 25-40-50: 10 bar **
MN • MBN • MBN-M DN 65-80-100: 5 bar **
MF • MBF • MBF-M DN 25-40-50: 10 bar **

MF • MBF • MBF-M DN 80-100: 5 bar **
MN-PST • MBN-PST • MBN-M-PST: 19.6 bar *
MF-PST • MBF-PST • MBF-M-PST: 19.6 bar *
MN-AP • MBN-AP • MBN-M-AP: 19.6 bar *
MF-AP • MBF-AP • MBF-M-AP: 19.6 bar *
MN-APA • MBN-APA • MBN-M-APA: 19.6 bar *
MF-APA • MBF-APA • MBF-M-APA: 19.6 bar *

* At average ambient temperature.

** PST version is available on request to allow a Maximum Operating Inlet Pressure = 19.6 bar at average ambient temperature.

Outlet Set Pressure Ranges

MN • MF: 10 to 500 mbar *
MN-PST • MF-PST: 0.2 to 0.5 bar
MN-AP • MF-AP: 0.5 to 1 bar
MN-APA • MF-APA: 1 to 3 bar

* For DN 80 and 100 the operating outlet set pressure range 0.01 to 0.08 bar is allowable with M...-BP version.

Minimum/Maximum Allowable Temperature (TS)

See label.

Functional Features

Accuracy class AC : up to ± 5%
Lock-up pressure class SG : up to +10%
Class of lock-up pressure zone SZ : up to 10%

Slam-Shut Controller

Accuracy class AG : ± 5%
Response time t_a : ≤ 1 s

Temperature

Standard version: Working -10° +60°C
Low temperature version: Working -20° +60°C

Materials

Flanges and covers: Steel
Diaphragm: Fabric NBR+PVC/Nitrile rubber
Pads: Nitrile (NBR) rubber

LABELLING

| BOLOGNA / ITALY | | CE | | Notified body XXXX | | APPARECCHIO TIPO / DEVICE TYPE | |
|------------------------------------|---|-------------------------------------|------|--------------------|-----|--------------------------------|----------------------|
| TARTARINI | | | | | | Note 1 | |
| MATRICOLA / ANNO SERIAL Nr. / YEAR | / Note 2 | | DN1 | | | | |
| REAZIONE FAIL SAFE MODE | FAIL OPEN <input checked="" type="checkbox"/> | FAIL CLOSE <input type="checkbox"/> | DN2 | | | | |
| NORME ARMONIZ. HARMONIZED STD. | EN | | Wds | bar | | | |
| CLASSE DI PERDITA LEAKAGE CLASS | | TIPO TYPE | Wdso | bar | | | |
| CLASSE FUNZIONALE FUNCTIONAL CLASS | | Cg | Wdsu | bar | | | |
| FLUIDO GRUPPO FLUID GROUP | 1 | pmax | bar | DN seat | | pdo | bar |
| TS | Note 3 | °C | PS | Note 4 | bar | PSD | Note 5 |
| | | | | | | | Bar PT= 1.5 x PS bar |

Figure 2. Label for M Series Regulators

Note 1: See “Characteristics”

Note 2: Year of manufacture

Note 3: Class 1: -10/+60 °C
Class 2: -20/+60 °C

Note 4: PN 16 PS = 16 bar
ANSI 150 PS = 19.3 bar

Note 5: 1.5 bar M...N-BP/80-100
4 bar all other types

OVERPRESSURE PROTECTION

The recommended maximum allowable pressures are stamped on the regulator nameplate. If actual version hasn't a built-in safety shut-off device, some type of overpressure protection is needed if the actual outlet pressure exceeds the actual maximum operating outlet pressure rating. Overpressure protection should also be provided if the regulator inlet pressure is greater than the maximum operating inlet pressure. Downstream side pressure after possible built-in SSD's intervention shall stay within the actual maximum operating set-up range to avoid anomalous back pressures that can damage the SSD's slam-shut controller. Downstream overpressure protection shall be also provided if the SSD outlet pressure can be greater than the PS of the SSD slam-shut controller (differential strength type). Regulator operation below the maximum pressure limitations does not preclude the possibility of damage from external sources or debris in the line. The regulator should be inspected for damage after any overpressure condition.

TRANSPORT AND HANDLING

Established transport and handling procedures shall be followed to avoid any damage on the pressure containing parts by shocks or anomalous stresses. Eyebolts are designed just for handling of equipment weight. Built-up sensing lines and pressure accessories (e.g. slam-shut controller) shall to be protected by shocks or anomalous stresses.

ATEX REQUIREMENTS

If the provisions of EN 12186 & EN 12279, national regulations, if any, and specific manufacturer recommendations are not put into practice before installation and if purge by inert gas is not carried out before equipment's start-up and shut-down operations, a potential external and internal explosive atmosphere can be present in equipment & gas pressure regulating/measuring stations/installations.

If a presence of foreign material in the pipelines is foreseen and purge by inert gas is not carried out, the following procedure is recommended to avoid any possible external ignition source inside the equipment due to mechanical generated sparks :

- drainage to safe area via drain lines of foreign materials, if any, by inflow of fuel gas with low velocity in the pipe-work (5m/sec)

In any case,

- provisions of Directive 1999/92/EC and 89/655/EC shall be enforced by gas pressure regulating/measuring station/installation's end user
- with a view to preventing and providing protection against explosions, technical and/or organizational measures appropriate to the nature of the operation shall be taken (e.g. : filling/exhausting of fuel gas of internal volume of the isolated part/entire installation with vent lines to safe area - 7.5.2 of EN 12186 & 7.4 of EN 12279 ; monitoring of settings with further exhaust of fuel gas to safe area ; connection of isolated part/entire installation to downstream pipeline;)
- provision in 9.3 of EN 12186 & 12279 shall be enforced by pressure regulating/measuring station/installation's end user
- external tightness test shall be carried out after each reassembly at installation site using testing pressure in accordance with national rules

periodical check/maintenance for surveillance shall be carried out complying with national regulations, if any, and specific manufacturer recommendations.

SLAM-SHUT CONTROLLER

The following controllers are used with M series regulator with built-in slam-shut:

- OS/66 Series spring loaded controllers



Figure 3. OS/66 Slam-Shut Controller

Table 2. OS/66 Characteristics

| MODEL | BODY RESISTANCE bar | OVERPRESSURE SET RANGE W_{oo} bar | | UNDERPRESSURE SET RANGE W_{ou} bar | |
|----------|---------------------|-------------------------------------|------|--------------------------------------|------|
| | | Min. | Max. | Min. | Max. |
| OS/66 | 6 | 0.022 | 0.6 | 0.007 | 0.45 |
| OS/66-AP | 6 | 0.2 | 5 | 0.1 | 2.5 |

Threaded 1/4" NPT female impulse connections.

Materials

Body and Cover: Aluminium

Diaphragm: NBR rubber

For further informations please see the Instruction Manual 0048EN-OS66-IM.

Type M

DIMENSIONS AND WEIGHTS

Table 3. Dimensions (mm) and Weights (kg) MN, MBN and MBN-M Regulators

| MN • MBN • MBN-M | | | | | | | | | |
|------------------|-----|------|-----------|-----|-----|--------------------------|--------|-----|-------|
| DN | I | A | | H | H1 | H2 MONITOR VERSION | WEIGHT | | |
| | | STD | AP APA | | | | MN | MBN | MBN-M |
| 25x65 | 184 | 380 | | 500 | 95 | 140 | 31 | 33 | 37 |
| 40x80 | 222 | 500 | 380 | 580 | 100 | 160 | 53 | 55 | 59 |
| 50x100 | 254 | | | 600 | 120 | 170 | 59 | 62 | 67 |
| 65x100 | 276 | | | 620 | 132 | 200 | 62 | 66 | 72 |
| 80x150 | 298 | 500 | 500 | 650 | 145 | 215 | 80 | 84 | 90 |
| | | 620* | | | | | | | |
| 100x200 | 352 | 500 | 500 | 660 | 180 | 265 | 125 | 130 | 140 |
| | | 620* | | | | | | | |

(*) BP Version

(**) For models with internal impulse connection only (DN 25, 40, 50, 65)

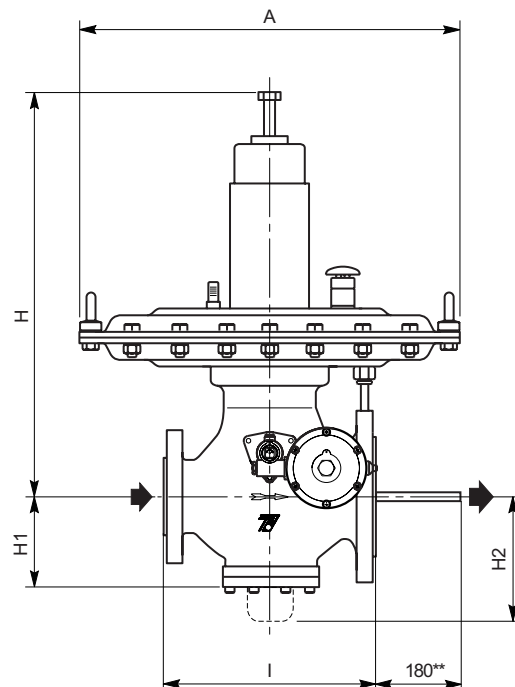

Table 4. Dimensions (mm) and Weights (kg) MF, MBF and MBF-M Regulators

| MF • MBF • MBF-M | | | | | | | | | |
|------------------|-----|------|-----------|-----|-----|--------------------------|--------|-----|-------|
| DN | I | A | | H | H1 | H2 MONITOR VERSION | WEIGHT | | |
| | | STD | AP APA | | | | MF | MBF | MBF-M |
| 25 | 184 | 380 | | 500 | 95 | 140 | 27 | 29 | 33 |
| 40 | 222 | 500 | 380 | 580 | 100 | 160 | 50 | 52 | 56 |
| 50 | 254 | | | 600 | 120 | 180 | 55 | 59 | 64 |
| 80 | 298 | 500 | 500 | 650 | 145 | 215 | 73 | 77 | 83 |
| | | 620* | | | | | | | |
| 100 | 352 | 500 | 500 | 660 | 180 | 265 | 110 | 115 | 125 |
| | | 620* | | | | | | | |

(*) BP Version

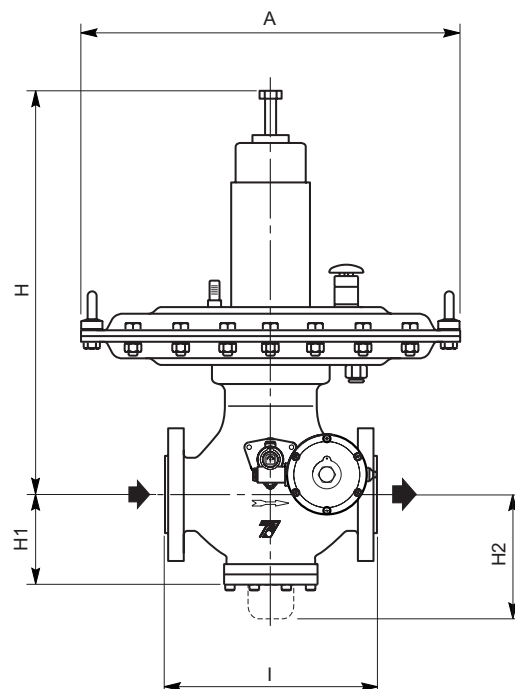

Figure 4. M Series Dimensions

OPERATION

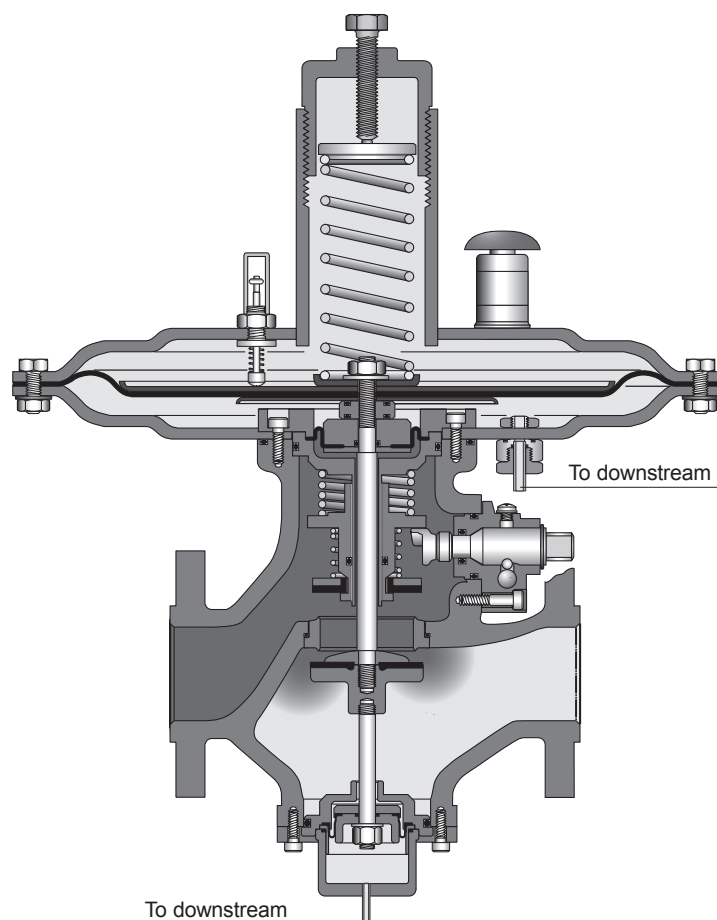

Figure 5. MBF-M Series Operational Schematic

How the Regulator Works

The range of position of control member depend from actuator assembly (spring-stem-diaphragm) movements.

The Diaphragm divides the Regulator control head into two chambers. The lower chambers is connected to regulated pressure P_d , and the other, where the spring regulator is located, is connected to atmospheric pressure.

When the contrasting actions of the spring and outlet pressure coincide, the mobile diaphragm-stem-valve assembly remains motionless, and outlet pressure matches spring set point.

An increase in capacity demand will cause a decrease in outlet pressure. This means that the spring's action will prevail over outlet pressure's action, and the valve will open until set point pressure is again reached at outlet.

The opposite occurs whenever outlet pressure increases.

Precision perfect balancing of control member is assured under all operating conditions by the inlet pressure which operates in the counterbalancing chamber.

How the Monitor Works

The monitor or emergency regulator is used as a safety device in gas pressure reduction systems. The purpose of this device is to protect the system against possible overpressure, while keeping the reduction line in service.

The monitor controls downstream pressure at the same point as the main regulator and is set a little higher than the latter.

Under normal duty, the monitor is fully open as it detects a pressure value lower than its set value. If, due to any regulator fault, downstream pressure increases, when it exceeds the tolerated level, the monitor comes into operation and adjusts pressure to its own set value.

For the OS/66 slam-shut controller operation please see the 0048EN-OS66-IM instruction manual.

Type M

INSTALLATION

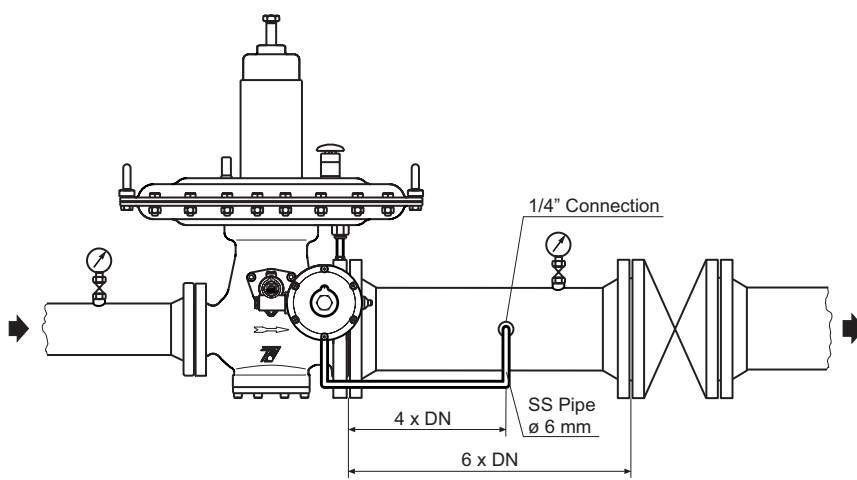

REGULATOR TYPE MBN DN 25 TO DN 65 WITH INTERNAL IMPULSE CONNECTION

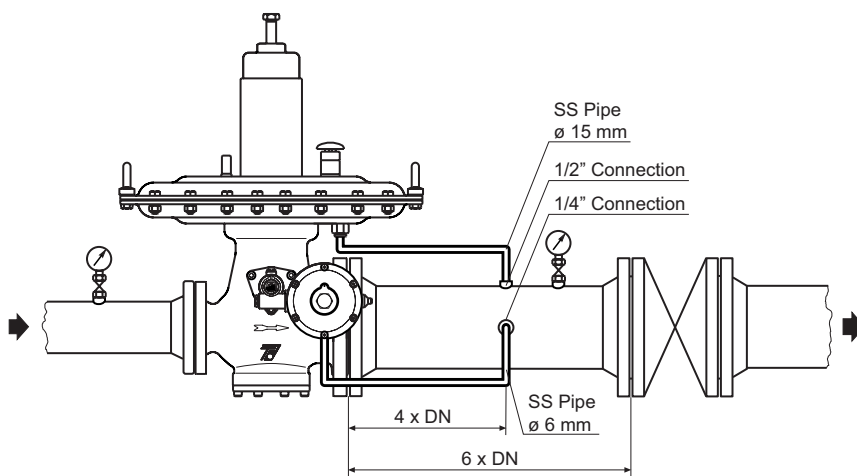

REGULATOR TYPE MBN DN 80 TO DN 100 WITH EXTERNAL IMPULSE CONNECTION

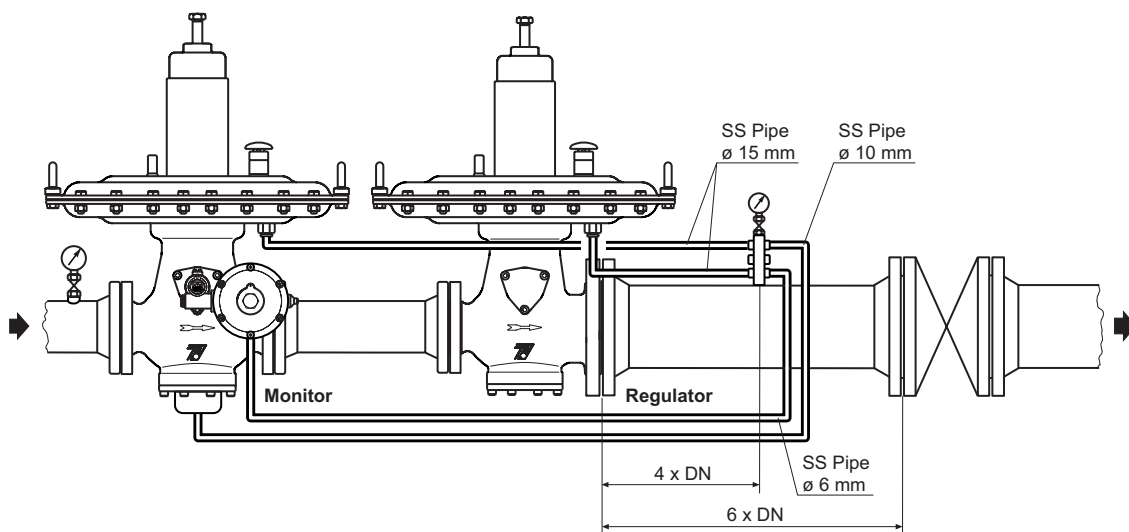

MONITOR TYPE MBF-M AND REGULATOR TYPE MN WITH EXTERNAL IMPULSE CONNECTIONS

Figure 6. Connection Schematics

- Ensure that the data found on the regulator plate are compatible with usage requirements.
- Ensure that the regulator is mounted in accordance with the direction of flow indicated by the arrow.
- Make the connections as indicated in figure 6.



WARNING

Only qualified personnel should install or service a regulator. Regulators should be installed, operated, and maintained in accordance with international and applicable codes and regulations. If the regulator vents fluid or a leak develops in the system, it indicates that servicing is required.

Failure to take the regulator out of service immediately may create a hazardous condition. Personal injury, equipment damage, or leakage due to escaping fluid or bursting of pressure-containing parts may result if this regulator is over pressured or is installed where service conditions could exceed the limits given in the “Characteristics” section, or where conditions exceed any ratings of the adjacent piping or piping connections.

To avoid such injury or damage, provide pressure-relieving or pressure-limiting devices (as required by the appropriate code, regulation, or standard) to prevent service conditions from exceeding limits. Additionally, physical damage to the regulator could result in personal injury and property damage due to escaping fluid. To avoid such injury and damage, install the regulator in a safe location.

Before installation, check if service conditions are consistent with usage limitations and if pilot set-up or possible built-in safety slam-shut device, is in accordance with service conditions of protected equipment.

All means for venting must be provided in assemblies where the pressure equipment is installed (ENs 12186 and 12279).

All means for draining must be provided for any equipment installed before regulators and slam-shut devices (ENs 12186 and 12279).

According to EN 12186 and 12279, where this product is used:

- Provide a cathodic protection and electrical isolation to avoid any corrosion;
- In accordance with clause 7.3/7.2 of aforesaid standards, the gas shall be cleaned by proper filters / separators /

scrubbers to avoid any technical and reasonable hazard of erosion or abrasion for pressure containing parts.

All pressure equipment should be installed in a non-seismic area and should not undergo fire and thunderbolt action.

All pipelines should be cleaned before installation of the regulator and checked that the regulator has not been damaged or contains foreign material after shipment.

Use suitable line gaskets and approved piping and bolting practices.

Install the regulator in a horizontal position, and check that flow through the body is in the direction indicated by the arrow on the body. Installation must be performed avoiding to create pressure force on the body and using suitable joint means according to equipment dimensions and service conditions.

The user should check and carry out any protection suitable for assembly’s specific environment.

Note: It is important that the regulator be installed so that the vent hole in the spring case is unobstructed at all times.

For outdoor installations, the regulator should be located away from vehicular traffic and positioned so that water, ice, and other foreign materials cannot enter the spring case through the vent.

Avoid placing the regulator beneath eaves or downspouts, and be sure it is above the probable snow level..

STARTUP

The regulator is factory set at approximately the midpoint of the spring range or the pressure requested, so an initial adjustment may be required to obtain desired results.

With proper installation completed:

- Slightly and very slowly open the outlet cut-off valve.
- In case of models fitted with slam-shut valve, relatch the valve by first loosening cap (C) and then screwing it onto the stem, after which pull cap outwards.
- By means of the appropriate wrench, hold stem pulled and slowly turn shaft (key 86) counterclockwise until balls (key 97 and 99) are felt to be clearly engaged, after which release wrench.
- Wait for outlet pressure to stabilize.
- Release the cap nut and remount it in original position.
- Finally, slowly open inlet and outlet cut-off valves fully.

Type M

ADJUSTMENT

To change the outlet pressure turn the adjusting screw (key. 1) clockwise to increase outlet pressure or counter clockwise to decrease pressure.

Monitor the outlet pressure with a test gauge during the adjustment.

SHUTDOWN



WARNING

To avoid personal injury resulting from sudden release of pressure, isolate the regulator from all pressure before attempting disassembly and release trapped pressure from the equipment and pressure line.

In case of disassembly of main pressure retaining parts for checks and maintenance procedures, external and internal tightness tests have to be done according applicable codes.

PERIODICAL CHECKS



CAUTION

It is recommended that checks be made periodically on the efficiency of the regulator.

Regulator Checking

Slowly close the outlet cut-off valve and check pressure in the length of pipe between the regulator and the valve.

If the system is functioning properly, an increase in outlet pressure will be noticed due to lock-up pressure, after which pressure will stabilize.

If, on the contrary, outlet pressure continues increasing, the system is not functioning properly due to improper valve disc tightness. In this case, close the valve located upstream of regulator and carry out maintenance procedures.

Slam-Shut Controller Checking (if installed)

See the Instruction Manual 0048EN-OS66-IM.

MAINTENANCE (SEE FIGURE 7)



WARNING

All maintenance procedures must be carried out only by qualified personnel. If necessary, contact our technical support representatives or our authorized dealers.

The regulator and its pressure accessories are subject to normal wear and must be inspected periodically and replaced if necessary.

The frequency of inspection/checks and replacement depends upon the severity of service conditions and according to applicable National or Industry codes, standards and regulations/recommendations.

In accordance with applicable National or Industry codes, standards and regulations/recommendations, all hazards covered by specific tests after final assembling before applying the CE marking, shall be covered also after every subsequent reassembly at installation site, in order to ensure that the equipment will be safe throughout its intended life.

Before proceeding with any maintenance work, shutoff the gas upstream and downstream from the regulator, also ensure that there is no gas under pressure inside the body by loosening the upstream and downstream connections.

Servicing does not require removal of valve from the line.

Replacing Seal Pad

- Unscrew the adjusting screw (key 1), unscrew the tube (key 3) and slide out the spring (key 66); unscrew the screws (key 29) and dismount the cap (key 28) or (key 126) for the monitor versions.
- Lock the stem (key 32) by inserting a suitable wrench in the appropriate slots (see letter **A** in Figure 7).
- Hold the stem locked and unscrew the pad holder (key 31).



CAUTION

This operation must be carried out with extreme care in order to avoid damage to the diaphragms.

Only for the monitor version before to dismount the pad holder (key 31) it is necessary to dismount the counterbalancing system:

Lock the monitor stem (key 130) by inserting a suitable wrench in the appropriate slots (see letter **B** in Figure 7) and dismount the nut (key 65). Disassemble all the parts of the counterbalancing system.

Check the shaped diaphragm (key 9), or the O-ring (key 7, 120 and 123 for the AP e APA versions). Hold the stem (key 32) locked and unscrew the monitor stem (key 130). Dismount the pad holder (key 31).

- Replace the pad (key 34). During this phase, the seat (key 35) and the O-ring (key 36) can be checked and replaced, if required. In order to do this, open slam-shut valve shutter and keep it open while unscrewing the seat with the appropriate wrench.

With the slam-shut valve shutter still kept open, mount a new seat.

- e. Reassemble the various parts by reversing the steps laid out above.

Reset Unit Maintenance

- a. Trip the slam-shut controller OS/66 and remove impulse connection. Then loosen and remove the screws (key 93 e 98) and take off the combined reset and controller unit.
- b. Loosen the dowels (G) and slide out the slam-shut controller from the reset unit.
- c. Unscrew the plug (key 104).
- d. Unscrew the stem (key 102) and remove the shaft (key 91), the spring (key 103), the slam-shut spring holder (key 105) and the O-Ring (key 106).
- e. Unscrew the plug (key 96) and remove the spring (key 94) and the balls (key 97 and 99).
- f. Remove the elastic pin (key 78), unscrew the dowel (key 89) and then slide out the shaft (key 85). Check the antifriction rings (key 76 and 80) and the O-ring (key 79); replace if required.
- g. Clean and check all components and replace if worn.
- h. Lubricate moving parts and reassemble by reversing the steps set out above. When reassembling the reset unit, make sure that cam (key 75) is to the right of the operator.

Upon completion of maintenance procedure, check opening of the slam-shut pad (key 39) by rotating the shaft (key 85) anticlockwise.

General Maintenance

- a. Remove the seal pad (key 34) as described in the previous paragraph.
- b. For the versions with slam-shut unscrew the screws (key 93 and 98) and remove the reset unit and the slam-shut controller OS/66 (key 134).
- c. Unscrew the screws (key 22) and the eyebolt (Key 48) and dismount the upper cover unit (key 61).
- d. Lock the stem (key 32) by inserting a suitable wrench in the appropriate slots (see letter **A** in Figure 7) and unscrew the nut (key 66).
- e. Dismount the plates (key 63, 62 and 17), dismount and check the diaphragm (key 21) and replace it if is worn.
- f. Unscrew the screws (key 14), slide out the plate (key 12) and the diaphragm tube (key 10).
- g. Dismount the assembly composed by the stem (key 32) and the shaped diaphragm (key 9); unscrew the spacer (key 6) and disassemble the various parts, check the shaped diaphragm (key 9) and the O-ring (key 5 and 7).

Only for the AP, APA and PST version slide out the piston (key 122) and the stem (key 32), check the O-ring (key 123) and the guide bush (key 121).

- h. Unscrew the screw (key 51), dismount the lower cover (key 25) and the cup unit (key 44).

CAUTION

For the versions with slam-shut keep attention to progressively unload the slam shut spring (key 26).

In case of the cup unit (key 44) being clogged due to oxidation or dust, remove it by inserting a puller in the appropriate threaded holes.

- i. Check the O-ring (key 15) and the antifriction rings (key 37).
- j. For the versions with slam-shut dismount the elastic ring (key 46) and disassemble the slam-shut parts; check the pad (key 39), the O-ring (key 41) and the antifriction ring (key 45), replace if required.
- k. Unscrew the seat (key 35) with the appropriate wrench and check the O-ring (key 36).
- l. Clean the various metallic parts with petrol and with compressed air. Replace worn parts.

For the OS/66 slam-shut controller maintenance please see the 0048EN-OS66-IM instruction manual.

Reassembling

Reassemble the various parts by reversing the steps laid out above. Attention should be made that each reassembled part moves freely and without friction.

In addition, care should be taken with regards to:

- a. Lubricating all moving parts and seals with "MOLYKOTE 55 M" grease and making sure that are not damaged during reassembly.
- b. Progressively and uniformly tightening all the screws so as to guarantee maximum seal.
- c. Setting the slam-shut valve and checking reset mode at end of reassembly.
- d. Checking for any leaks by using soapy water.

SPARE PARTS

Spare parts storage shall be done by proper procedures according to national standard/rules to avoid over aging or any damage.

Type M

TROUBLESHOOTING

Table 5. M Series General Troubleshooting

| SYMPTOMS | CAUSE | ACTIONS |
|--|--|---|
| The regulator does not open | Lack of incoming gas | Check the station feeding |
| | The slam-shut controller has not been reset | Manually reset the slam-shut controller |
| Drop in pressure downstream from the regulator | Insufficient upstream pressure | Check the station feeding |
| | Flow requirements higher than the flow that the regulator can supply | Check the regulator sizing |
| | Filter upstream is obstructed | Clean or replace the filter |
| | Broken spring | Replace the spring |
| Increase in pressure downstream from the regulator or safety devices being activated (slam-shut valve) | Tight shutoff gaskets are worn | Replace gaskets |
| | Deposits of grime on the tight shutoff pad are obstructing proper positioning of the shutter | Clean or replace the pad |
| | Diaphragm damaged | Replace the diaphragm |
| Slam-shut device does not execute tight shutoff procedure | O-ring and/or slam-shut pad worn | Replace the O-ring or/and the slam-shut pad |
| | Slam-shut seat damaged | Replace the slam-shut seat |

PARTS LIST

Key Description

| | | | | | |
|-----|-------------------------|-----|-------------------------|------|----------------------------|
| 1 | Adjusting Screw | 46 | Elastic ring | 93 | Screw |
| 2 | Upper spring holder | 47* | Gasket | 94 | Spring |
| 3 | Tube | 48 | Eyebolt | 95* | Gasket |
| 4 | Label | 49* | O-ring | 96 | Plug |
| 5* | O-ring | 50 | Plug | 97 | Ball |
| 6 | Spacer | 51 | Screw | 98 | Screw |
| 7* | O-ring | 52 | Diaphragm hub | 99 | Ball |
| 8 | Plate | 53 | Diaphragm | 100 | Screw |
| 9* | Shaped Diaphragm | 54 | Pawl | 101* | O-ring |
| 10 | Diaphragm tube | 55 | Spring | 102 | Stem |
| 11 | Plate | 56 | Bush | 103 | Spring |
| 12 | Plate | 57 | Travel indicator | 104 | Plug |
| 13 | Vibrations dumper | 58 | Label | 105 | Slam-shut spring holder |
| 14 | Screw | 59 | Label | 106* | O-ring |
| 15* | O-ring | 60 | Sheath | 107 | Screw |
| 16* | O-ring | 61 | Upper cover unit | 108 | Plug |
| 17 | Plate | 62 | Spring holder plate | 109 | Plug |
| 18 | Plug | 63 | Spring holder plate | 110 | Connection |
| 19 | Special nut | 64 | Washer | 113 | Special washer |
| 20* | O-ring | 65 | Autolocking nut | 117* | O-ring |
| 21* | Diaphragm | 66 | Spring | 118* | O-ring |
| 22 | Screw | 67 | Connection | 119 | Plug |
| 23 | Washer | 68* | O-ring | 120* | O-ring |
| 24 | Nut | 69 | Impulse pipe connection | 121 | Guide bush |
| 25 | Lower cover | 70 | Extension | 122 | Piston |
| 26 | Spring | 71 | Impulse pipe | 123* | O-ring |
| 27* | O-ring | 72 | Connection | 124 | Plate |
| 28 | Cap | 75 | Cam | 125 | Connection |
| 29 | Screw | 76* | Antifriction ring | 126 | Monitor cap |
| 30 | Body | 77 | Bush | 127 | Monitor plate |
| 31 | Pad holder | 78 | Elastic pin | 128* | O-ring |
| 32 | Stem | 79* | O-ring | 129 | Monitor cup |
| 33 | Pad retainer | 80* | Antifriction ring | 130 | Monitor stem |
| 34* | Pad unit | 81* | O-ring | 132 | Disco |
| 35 | Seat | 82 | Plug | 133 | SR silencer |
| 36* | O-ring | 83* | O-ring | 134 | OS/66 Slam-shut controller |
| 37* | Antifriction ring | 84 | Elastic ring | 135 | Washer |
| 38 | Pad holder | 85 | Shaft | 150 | Reset lever unit |
| 39* | Pad | 86 | Label | | |
| 40 | Spring | 87 | Rivet | | |
| 41* | O-ring | 88 | Hub | | |
| 42 | Slam-shut spring holder | 89 | Screw | | |
| 43 | Slam-shut shutter | 90* | O-ring | | |
| 44 | Cup unit | 91 | Shaft | | |
| 45 | Connection | 92* | O-ring | | |

Rubber parts marked with (*) are supplied in the "spare parts kit", recommended as stock.

To order the kit it is necessary to communicate to us the type of the regulator and its serial number.

SCHEMATIC ASSEMBLIES

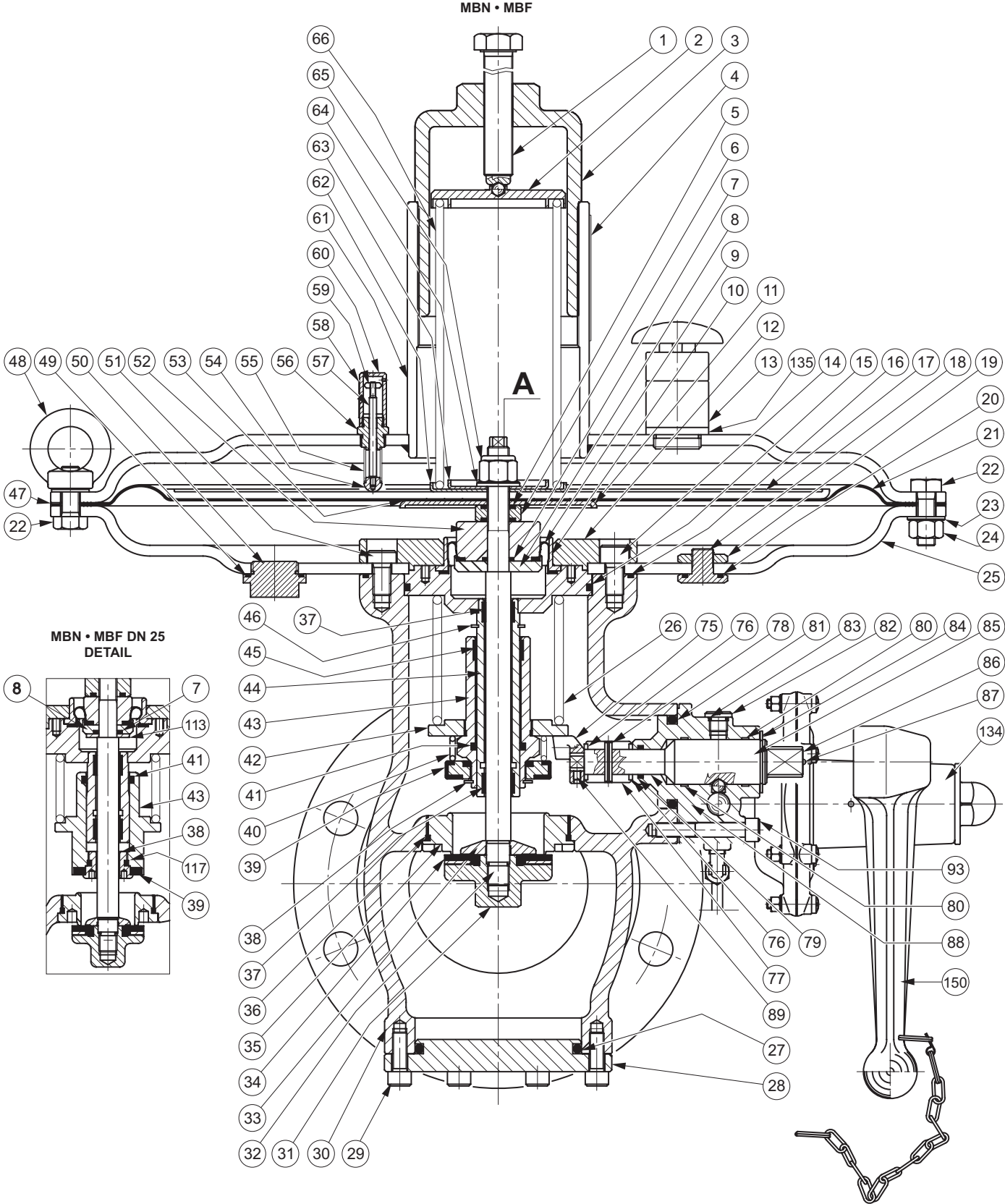

LM/1392

Figure 7. M Series Regulator Assembly

Type M

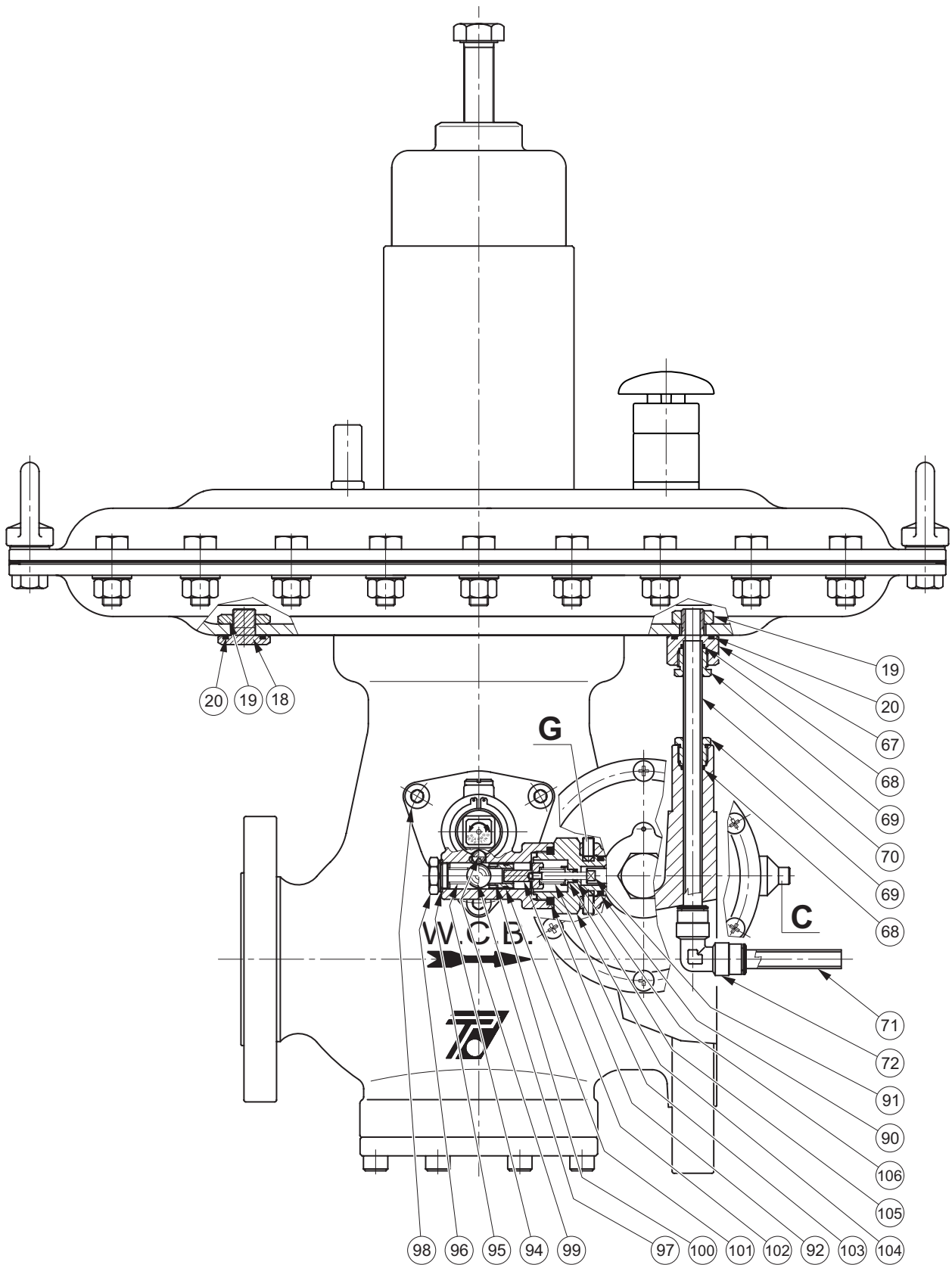

LM/1392

Figure 7. M Series Regulator Assembly (continued)

EXTERNAL IMPULSE LINE DETAIL

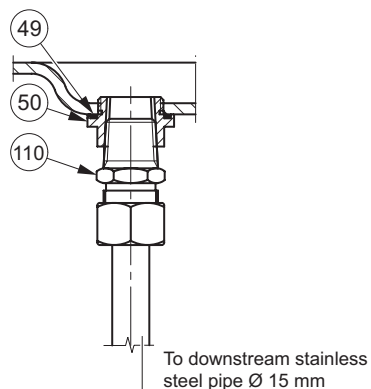

MN • MBN DN 80 TO DN 100 MBN-M DETAIL

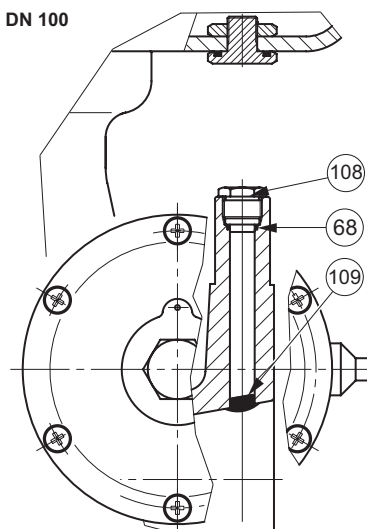

MN • MF DN 25 DETAIL

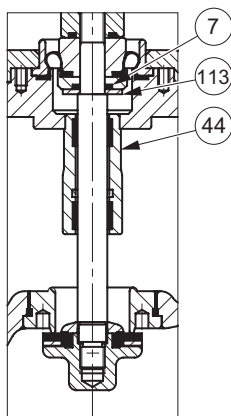

MN • MF DN 40 TO DN 100 DETAIL

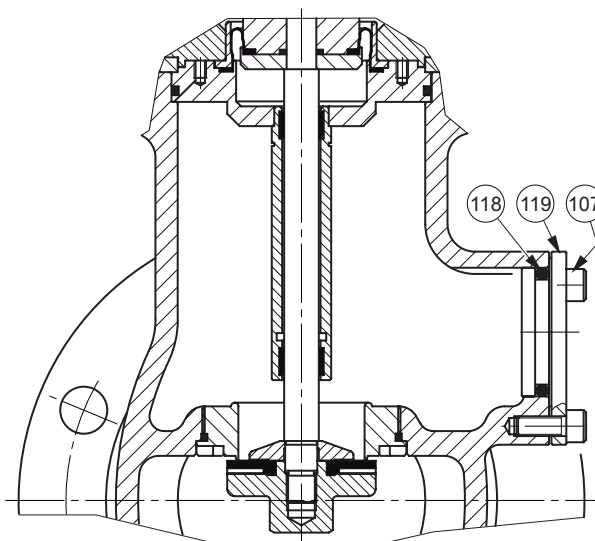

DN 25 TO DN 100 AP, APA AND PST VERSION

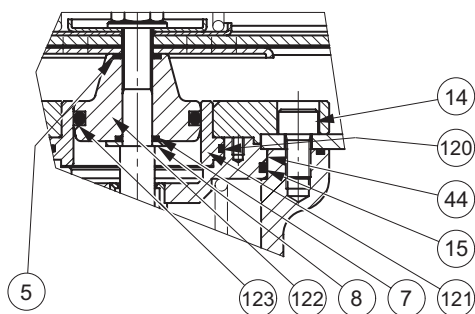
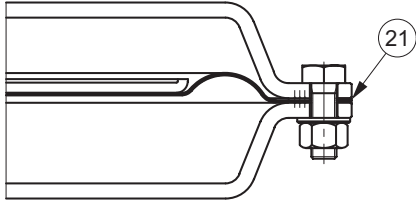

Figure 7. M Series Regulator Assembly (continued)

Type M

DN 25 DETAIL



DN 100 DETAIL

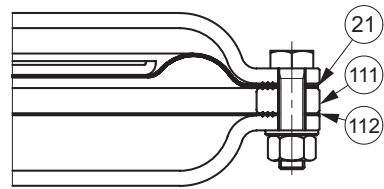

DN 100 AP VERSION

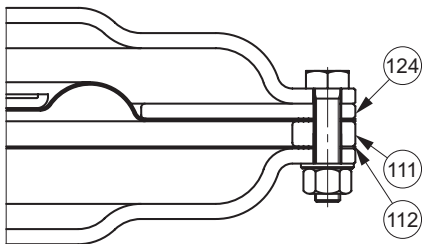

DN 100 PST VERSION

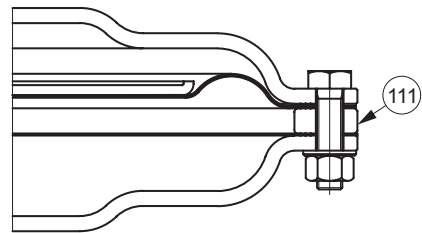

DN 25 TO DN 80
APA VERSION

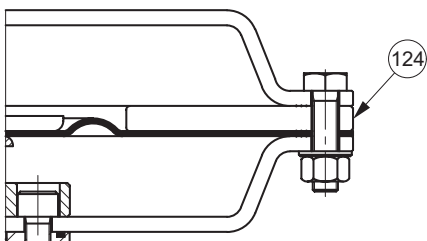

DN 100 APA VERSION

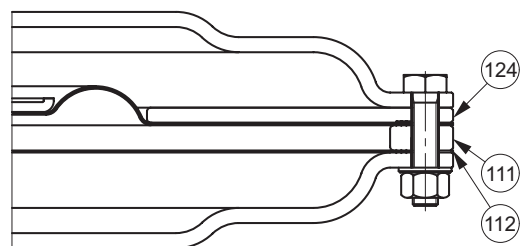
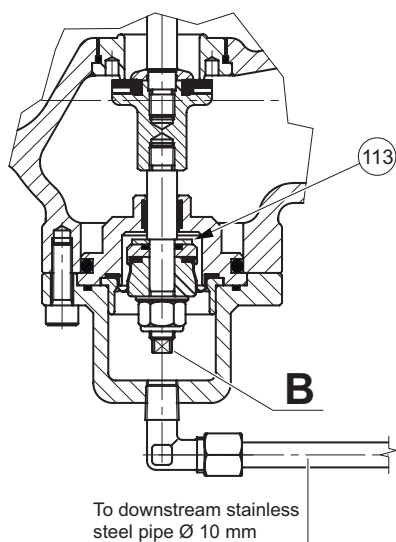
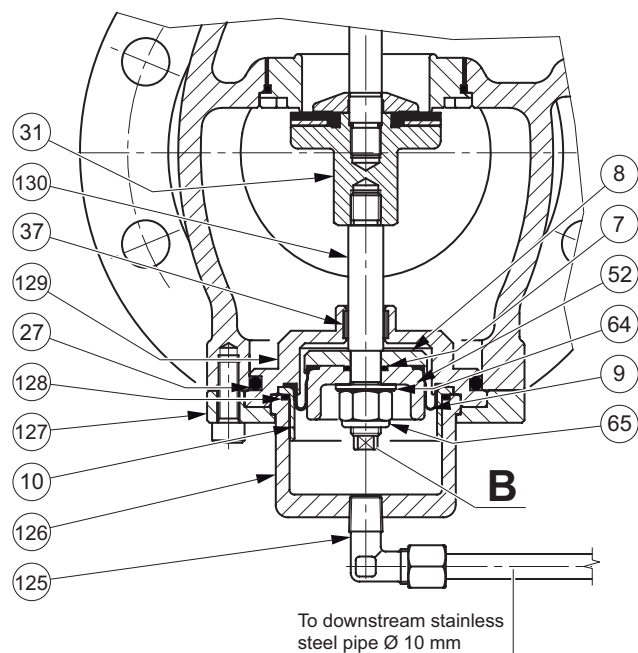

Figure 7. M Series Regulator Assembly (continued)

DN 25 MONITOR VERSION



DN 40 TO DN 100 MONITOR VERSION



AP AND APA MONITOR VERSION

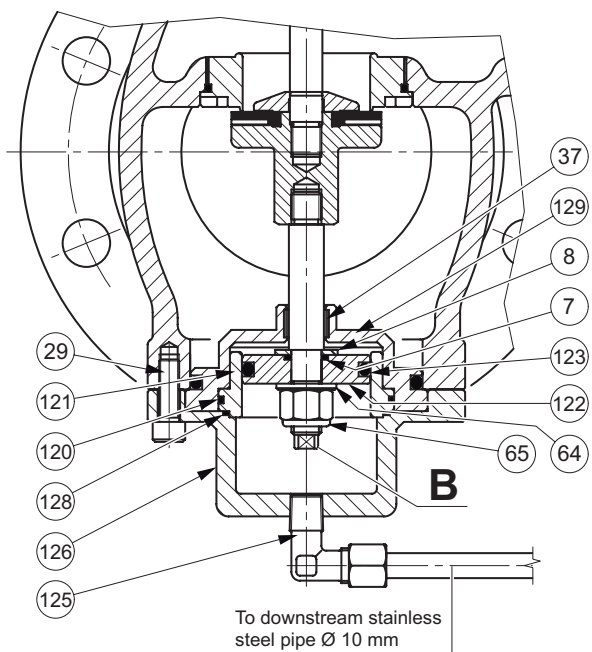

SR SILENCED VERSION DETAIL

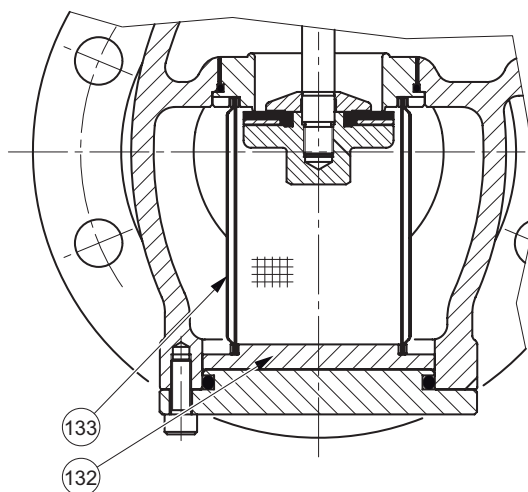

Figure 7. M Series Regulator Assembly (continued)

Type M

Industrial Regulators

Emerson Process Management Regulator Technologies, Inc.

USA - Headquarters
McKinney, Texas 75070, USA
Tel: +1 800 558 5853
Outside U.S. +1 972 548 3574

Asia-Pacific
Shanghai 201206, China
Tel: +86 21 2892 9000

Europe
Bologna 40013, Italy
Tel: +39 051 419 0611

Middle East and Africa
Dubai, United Arab Emirates
Tel: +971 4811 8100

Natural Gas Technologies

Emerson Process Management Regulator Technologies, Inc.

USA - Headquarters
McKinney, Texas 75070, USA
Tel: +1 800 558 5853
Outside U.S. +1 972 548 3574

Asia-Pacific
Singapore 128461, Singapore
Tel: +65 6777 8337

Europe
O.M.T. Tartarini s.r.l. Via P. Fabbri 1,
I-40013 Castel Maggiore (Bologna), Italy
Tel: +39 051 419 0611
Francel SAS, 3 ave Victor Hugo,
CS 80125 - Chartres 28008, France
Tel: +33 2 37 33 47 00

Middle East and Africa
Dubai, United Arab Emirates
Tel: +971 4811 8100

TESCOM

Emerson Process Management Tescom Corporation

USA - Headquarters
Elk River, Minnesota 55330-2445, USA
Tels: +1 763 241 3238
+1 800 447 1250

Asia-Pacific
Shanghai 201206, China
Tel: +86 21 2892 9499

Europe
Selmsdorf 23923, Germany
Tel: +49 38823 31 287

For further information visit www.emersonprocess.com/regulators

The Emerson logo is a trademark and service mark of Emerson Electric Co. All other marks are the property of their prospective owners. Tartarini is a mark of O.M.T. Officina Meccanica Tartarini s.r.l., a business of Emerson Process Management.

The contents of this publication are presented for informational purposes only, and while every effort has been made to ensure their accuracy, they are not to be construed as warranties or guarantees, express or implied, regarding the products or services described herein or their use or applicability. We reserve the right to modify or improve the designs or specifications of such products at any time without notice.

Emerson Process Management Regulator Technologies, Inc., does not assume responsibility for the selection, use or maintenance of any product. Responsibility for proper selection, use and maintenance of any Emerson Process Management Regulator Technologies, Inc., product remains solely with the purchaser.

O.M.T. Officina Meccanica Tartarini S.R.L., R.E.A 184221 BO Cod. Fisc. 00623720372 Part. IVA 00519501209 N° IVA CEE IT 00519501209,
Cap. Soc. 1.548 000 Euro i.v. R.I. 00623720372 - M BO 020330

Francel SAS, SIRET 552 068 637 00057 APE 2651B, N° TVA : FR84552068637, RCS Chartres B 552 068 637, SAS capital 534 400 Euro