

June 2017

RELEASE RELAY

CONTENTS

Release Relay (Type OS2)	1 to 3
Introduction	1
Mechanism Box (BM)	1
Safety Manometric Box (BMS)	1
Characteristics	2
Labelling	2
Types of Installation	3
Dimensions and Weights	3
Mechanism Box (BM)	4 to 8
Description and Spare Parts	4
Operation	5
Connections	6
Materials	6
Commissioning	6
Maintenance	7
Options	7
Safety Manometric Box (BMS)	8 to 15
Description and Spare Parts	8
Operation	9
Connections	9
Spring Adjustment Ranges	10
Materials	12
Adjustment	12
Maintenance	14

INTRODUCTION

The Type OS2 Release Relay consists of a Mechanism Box (BM) and one or two Safety Manometric Boxes (BMS). Its function is to provoke the activation of a slam shut valve which may be stand alone (Type OSE), integrated in a regulator (Types MP, MPS, DRPNPIL, EZH, DRPN and EZR) or integrated in a Type K1000/K3000, in the case of under or over pressure in the controlled gas network. It may be mounted on systems of DN 25 to DN 150 and up to PN 100.

It is tight shut and submersible. It may be connected to an explosion-proof contact (intrinsically safe).

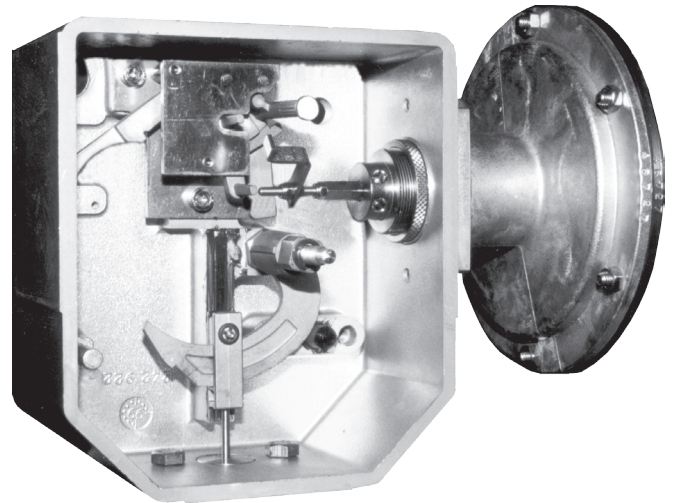

Figure 1. Type OS2

MECHANISM BOX (BM)

The mechanism box is designed to close a slam shut valve. The operation is ensured in two successive stages: a detection stage and a power stage. The separation between the detection stage and the power stage provides maximum precision, indifferent of working pressure, slam shut valve diameter and gas flow. After activation of the slam shut valve due to over or under pressure, the mechanism box must be reset manually. The complete system is available, on request only, sealed with lead and wire.

SAFETY MANOMETRIC BOX (BMS)

The pressure data is transformed into a displacement by a safety manometric box (Type **BMS 1**) mounted on the mechanism box (**BM**). This displacement is used to activate the detection stage of the mechanism box in the case of overpressure, over or underpressure, or underpressure condition.

In certain configurations, a second box may be used (Type **BMS 2**).

Type OS2

CHARACTERISTICS

Accuracy	AG 2.5	Diaphragm or bellows
	AG 5	Piston
Memorization	No memorization	
Resistance to vertical shocks	4 J	(20 shocks)
Resistance to pendular shocks	9.81 J	
Sealing	IP 67	Temporary immersion
Maximum operating pressure (PSD)	100 bar	
Operating temperature	-30°C to +71°C	
Maximum valve travel	50 mm	

Table 1. Type OS2 Pressures

Size	162	071	027	017	236	315
PSD	10 bar	20 bar	100 bar	100 bar	35 bar	72 bar
AG max.	2.5	2.5	5	5	2.5	2.5

See Tables 14, 15 and 16 for other values.

Connections

Table 2. Connection Types

Non connectable	Plastic vent with screen	1/4" NPT
Connectable	Link 8/10 tube	
Contact	Box exit	1/2" NPT

LABELLING

BMS Taille Size	See Table 1	PSD BMS	See Table 1	bar
N° Série Serial		AG maxi	See Table 1	
Fisher	Ressort/Spring Ø			mm
		$\Delta 1$		bar

Figure 2. Max. Pressure Triggering

BMS Taille Size	See Table 1	PSD BMS	See Table 1	bar
N° Série Serial		AG maxi	See Table 1	
Fisher	Ressort/Spring Ø			mm
Wdsu		$\Delta 1$		bar

Figure 3. Min. Pressure Triggering

BMS Taille Size	See Table 1	PSD BMS	See Table 1	bar
N° Série Serial		AG maxi	See Table 1	
Fisher	Ressort/Spring Ø			mm
Wdsu Wdso		$\Delta 1$		bar
		$\Delta 2$		bar

Figure 4. Max. and Min. Pressure Triggering

TYPES OF INSTALLATION

Mounting on horizontal pipeline only:

Top Mounted (stand-alone valve)

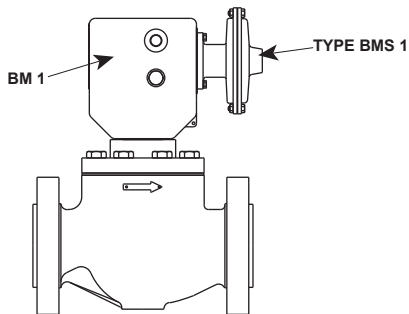

N01

Figure 5. BM 1: Mechanism Box with One Safety Manometric Box (Type BMS 1)

Bottom Mounted (intergrated valve and regulator)

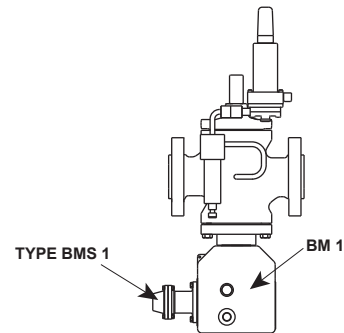

N03

Figure 6. BM 1: Mechanism Box with One Safety Manometric Box (Type BMS 1)

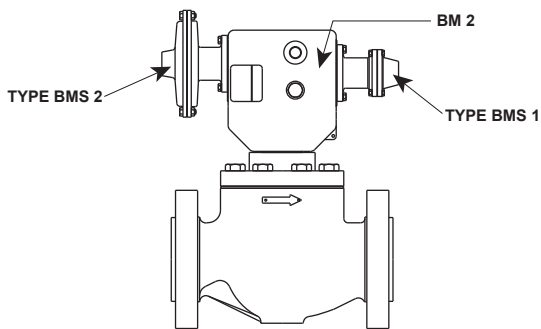

N02

Figure 7. BM 2: Mechanism Box with Two Safety Manometric Boxes (Types BMS 1 and BMS 2)

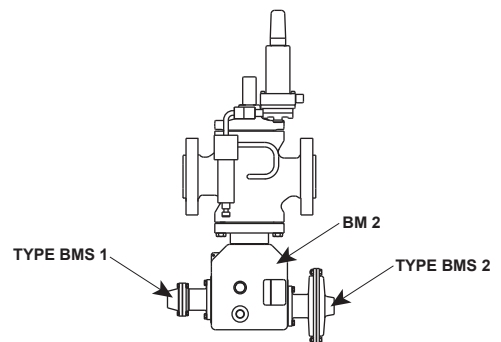

N04

Figure 8. BM 2: Mechanism Box with Two Safety Manometric Boxes (Types BMS 1 and BMS 2)

DIMENSIONS AND WEIGHTS

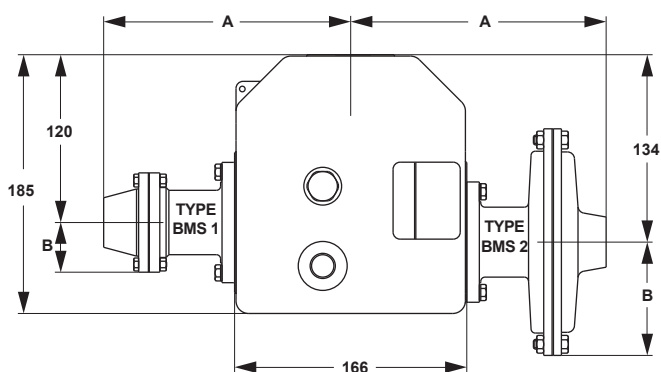

N05

Figure 9. Dimensions

Table 3. Dimensions and Weights

	Type	Dimensions, mm		Weight, kg	
		A	B		
BM	BM1	For 1 BMS		2.5	
	BM2	For 2 BMS		2.5	
BMS	162	Diaphragm	181	83	2.6
	71	Diaphragm	175	36	1.2
	27 or 17	Piston	204	36	2.3
	236	Bellows	202	36	2.4
	315	Bellows	223	36	2.8

For a Type OS2 with one BMS add the weight of the BMS to that of the BM 1.
For a Type OS2 with two BMS add the weight of the two BMS to that of the BM 2.

Type OS2

DESCRIPTION AND SPARE PARTS (BM)

Table 4. Mechanism Box Assembly

Item	Description	BM1	BM2
	Mechanism box	FA181067T12	FA181068T12
1	Cap including indicator, O-ring and screw (new version 06/2007; interchangeable)	FA181328T12	
	New cap O-ring	FA145430X12	
2	Mechanism box casing	FA142930X12*	FA144071X12
3	Box gasket	FA142930X12*	
	BMS gasket	FA145431X12*	
	BMS screw	FA402018X12*	
	BMS sealing screw O-rings	FA461150X12*	
4	Non-connectable brace vent	27A5516X012	
	Vent link for 8 x 10 tube	FA406526X12	
5	Yoke	FA181042X12	
6	Fixed bolt axe (do not dismount)	FA142920X12	
	Bolt	FA181043X12	
	Truarc O-ring	FA406128X12	
7	Travel stop	FA140324X12	
	Damper	FA127692X12	
8	Mechanism	FA181041X12	
	Mechanism screw	FA402512X12	
9	Resetting tool	FA242915T12	

* Sold as a set ref. n° FA197351X12.. Items in bold are spare parts.

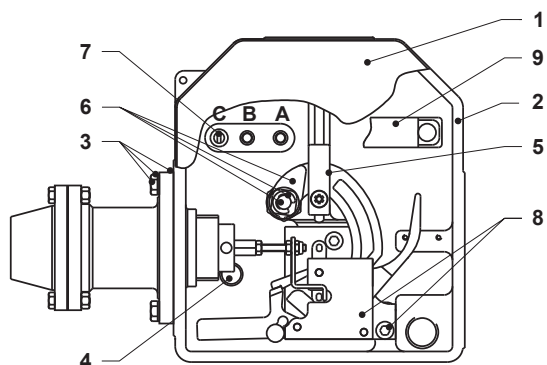

Figure 10. Mechanism Box for One BMS

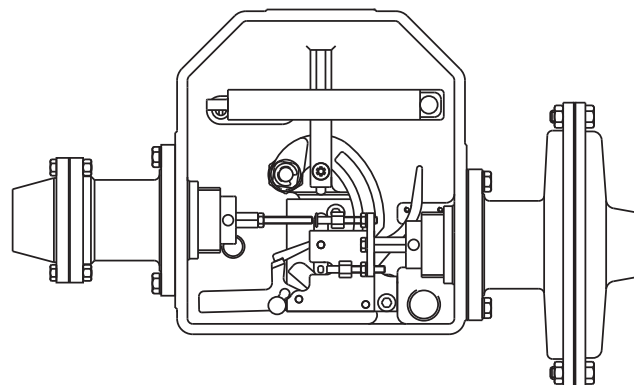

Figure 11. Mechanism Box for Two BMS

N06

Table 5. Packing Gland Assembly

Description	Packing gland		
	Valve		
	Type OSB	Type VSE	Standard
Assembly	FA181089X12	FA181090X12	FA181104X12
Packing gland and stem	FA181040X12	----	FA181040X12
Packing gland	----	144 126	----
O-ring	FA400514X12	FA400505X12	FA400514X12
O-ring	----	FA400221X12	----
Fastening screw H M7	FA402028X12	----	FA402028X12
Fastening screw H M8	----	FA402036X12	FA402036X12
Flat washer (key 7)	FA405005X12	----	FA405005X12
Flat washer (key 8)	----	FA405006X12	FA405006X12

Items in bold are spare parts.

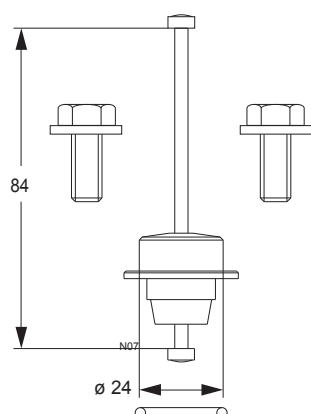

Figure 12. Standard Packing Gland

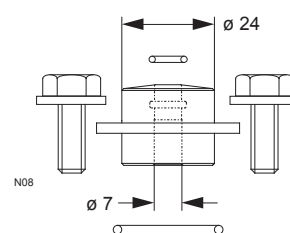

Figure 13. Type VSE Packing Gland

OPERATION (BM) (FIGURE 14)

The detection stage consists of two parts:

- The releasing stem (key 1)
- The 1st stage trigger (key 2).

Through the intermediate of the safety manometric box (BMS), the pressure provokes a pin movement (D1 or D2), which provokes the rotation of the releasing stem (key 1) and frees the 1st stage trigger (key 2).

The power stage consists of two parts:

- The 2nd stage trigger (key 3)
- The cam (key 4).

The 2nd stage trigger (key 3), activated by the 1st stage trigger (key 2), frees the cam (key 4), which provokes the valve to close. After release, the resetting is ensured in two stages: (detection stage, then power stage) see «commissioning».

Position indicator

The position of the detection stage can be seen through the position indicator glass.

Memorization

The releasing stem will only start moving when pressure approaches the pressure setpoint. In all other cases, it remains fixed. Furthermore the assembly has a very high resistance to shocks. If pressure approaches the setpoint, the releasing stem turns, but with the slightest shock or vibration it will go back to its initial position and pressure returns to normal. The mechanism is said to be non memorizing.

Resistance to shocks

This assembly has a remarkable resistance to shocks (20 vertical shocks of 4 J and 20 pendular shocks of 9.81 J), with pressure close to setpoint (for example: 186 mbar for a setpoint of 200 mbar).

Type OS2

CONNECTIONS (BM)

- Fixation BM / Connector:
 - H M7 or H M8 screws
 - 16 N•m torque
- Sealed BM / Connector:
 - Flat O-ring (water resistant)
 - Packing gland (gas resistant)
- Mechanism contact / Slam shut valve:
 - Control rod
- BM connector / atmosphere:
 - Integrated vent nipple with screen (supplied) or compression fitting (supplied) for 8/10 tube (not supplied)*
- Electrical connections:
 - See table 9

* The 8/10 tube should be angle-shaped on the top to avoid water from entering.

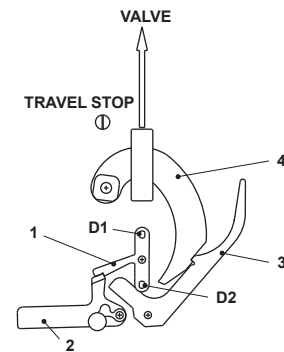

Figure 14. Mechanism Details

MECHANISM BOX (BM) MATERIAL

Table 6. Mechanism Box (BM) Material

Box	Body	Aluminum	Chromatation
	Cover	Aluminium	Chromatation
	Position indicator	Polycarbonate	
	Self-jamming ring	Steel	Phosphatation
	Cover nut	Stainless steel	
	Circlips	Steel	Phosphatation
Mechanism	All parts	Stainless HR	
	Brackets	Brass	
	Bolt	Brass	
	Elastic O-ring	Steel	Phosphatation
	Torsion spring	Stainless steel	
	Traction spring	Bronze	
Yoke	Self-jamming ring	Steel	Phosphatation
O-rings	Flat	EPDM	
	Cover	Neoprene (CR)	
	Truarc ring	Nitrile (NBR)	

Table 7. Packing Gland Material

Body	Bronze	
Control rod	Stainless steel	Chromium plating
Truarc ring	Nitrile (NBR)	

COMMISSIONING (BM)

WARNING

AUTHORIZED PERSONNEL ONLY
Risk of injury

After rearming, remove the reset key from the stem. Do not put fingers in or near the reset mechanism area.

CAUTION

Never use an extension pipe with the reset key when resetting the 2nd stage (max. normal torque 16 N•m, never go over 32 N•m).

Commissioning differs depending on whether the assembly has an internal or external bypass and whether overpressure releasing is required or not. See corresponding technical manuals for further details.

Note

The position of the travel stop (figure 10, key 7) depends on the type of assembly and its size. Position A, B or C depending on max. travel of slam shut valve: A = 15 mm travel, B = 35 mm travel, C = 50 mm travel.

• Mechanism box (BM) intervention

To access the box the cover must be removed. When unscrewing the nut a circlips is used to remove the O-ring. The cover is held on by one screw which can be unscrewed manually or using a socket screw key (recommended torque for optimal shutoff: 6 N•m).

• Resetting

To reset the slam shut (after the fault has been settled), the 1st mechanism stage must be reset by manually turning the 1st stage trigger. If the slam shut has an internal bypass the

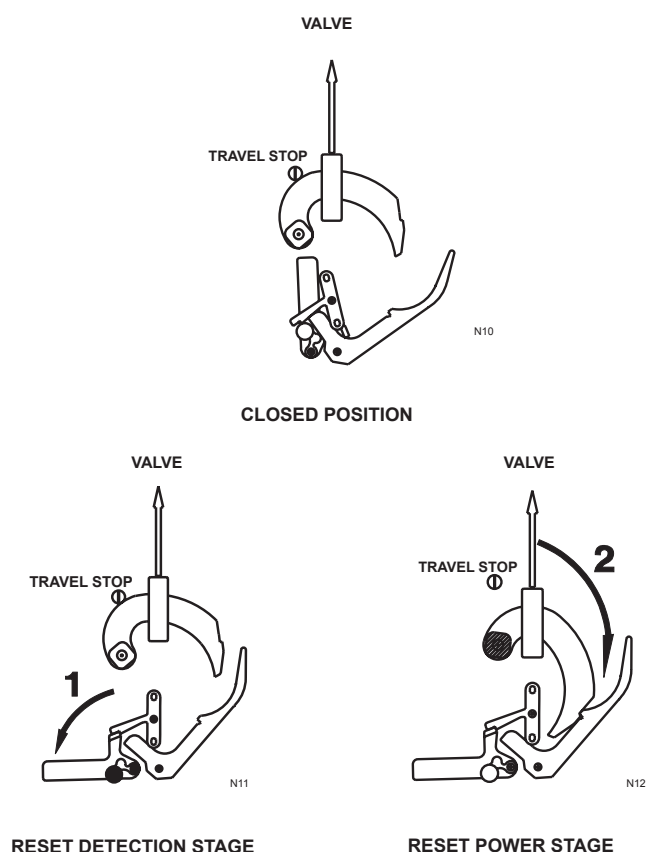

Figure 15. Release Activation Stages

cam must be slightly turned using a resetting key to bypass. If the slam shut has an external bypass, a bypass valve will be used. In both cases:

- Wait for the pressure to be equalized before resetting the 2nd mechanism stage.
- When resetting the 2nd mechanism stage (opening of the valve) a reset key is used (delete).

MAINTENANCE (BM)

Tools:

- Spanner 11 (screw 7) and 13 (or 14) (screw 8)
- Screwdriver

Control:

- 1st and 2nd stage mechanism releasing
- Packing gland is tight shut
- Yoke greasing

Disassembly:

- Check that assembly is not under pressure
- Manual release of slam shut (figure 14)
- Manually press on the releasing stem pin D1 or D2 (figure 14, key 1) parallel to the BMS axe

- Unscrew the travel stop (screwdriver)
- Unscrew the BM fastening screws (flat spanner 11 (screw 7) and 13 (or 14) (screw 8))
- Disassemble the mechanism box (BM) from the connector by unlocking the yoke

Assembly :

- Proceed in reverse order to disassembly

OPTIONS (BM)

- **Remote alert (on BM1 or BM2)**
Detects 2nd stage releasing (power)
- **Remote control**
Atmospheric solenoid valve (releasing by min. pressure) for max. releasing pressure of 30 bar. Safety manometric box (BMS) activated with a pneumatic or electro-pneumatic impulse.
- **Manual control on BM2 with 1 Type BMS 1 only**
Push button (connected at the same place as a Type BMS 2).
- **Contact**

Table 8. Mechanism Box (BM) Contact

	AC	DC
Max. intensity	7.0 A	0.8 A
Max. tension	400 V	250 V
Protection	EEx-d IIC T6	
Tightness	IP 66	
Temperature	- 29° C + 71° C	
Fastening	2 M3 screws	
Cable	3 wires (black, brown, blue) H05VVF (3 x 0.75 mm ²) D 6.5 mm	

Type OS2

Table 9. Mechanism Box (BM) Versions

Versions	Installation	Sealing	Connection	Mechanical Connections	Electrical Connections			
					Common	NF	NO	Connection
C0		IP 68	Sans	1/2 NPT cap				
C1	ADF	IP 68	ADF	3 m wire	Black	Blue	Brown	Wires
C2	ADF	IP 65	ADF	Explosion proof connector box/PE	3	4	5	Screwed wiring
C3	SI	IP 68	ADF	Intrinsical safe tight-shut connector	A	B	C	Welded wiring

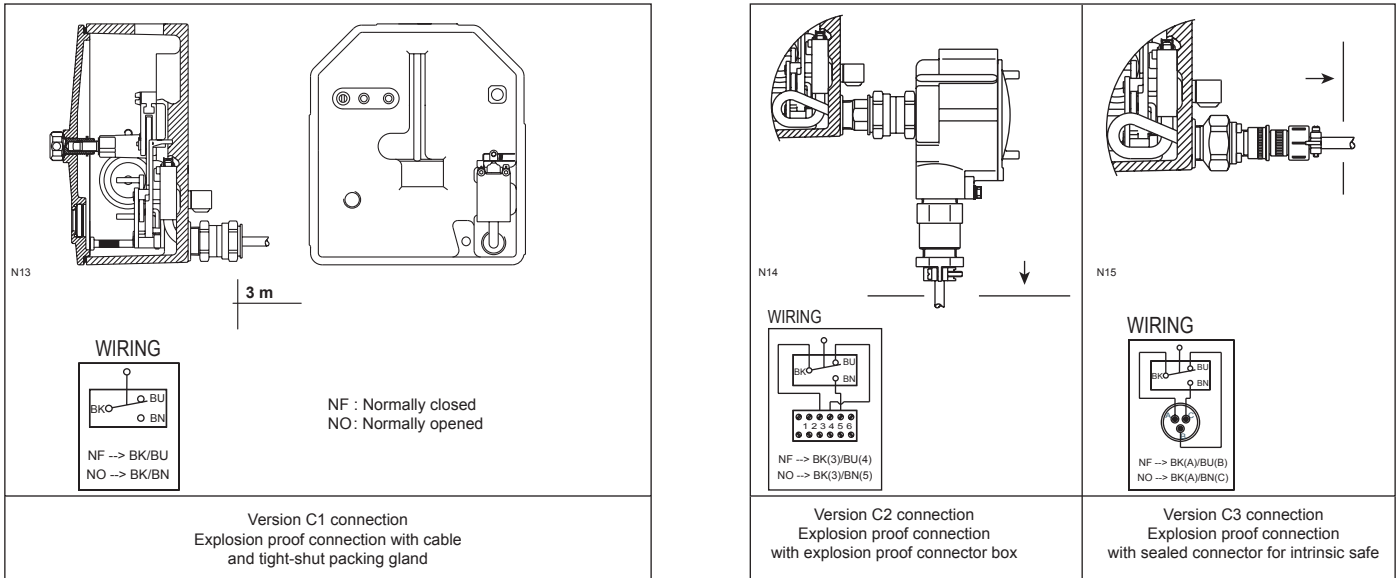

Figure 16. Different Versions of BM Connections

SAFETY MANOMETRIC BOX (BMS) DESCRIPTION AND SPARE PARTS

• Impulse line

The impulse line (IS) is connected to the network to be protected (normally downstream of the regulator).

• Impulse type

Depending on the pressure and precision required, different types of impulse may be used: Diaphragm, Piston or Bellows.

• Springs

To cover all pressure ranges, a set of springs of equal length and diameter, but of different wire diameter (2 to 6.5 mm), may be used.

• Detection

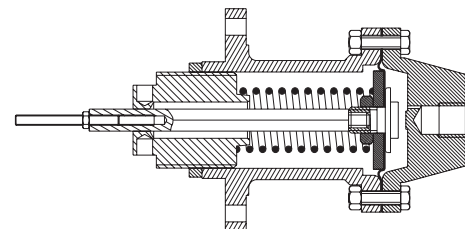

Figure 17. Type BMS 1 Max. Only

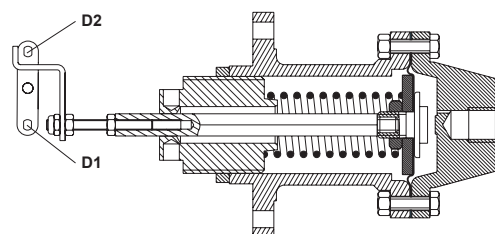

Figure 18. Type BMS 1 Min. Only

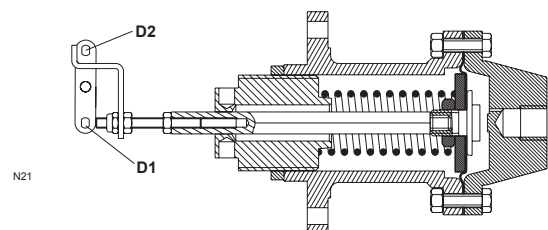
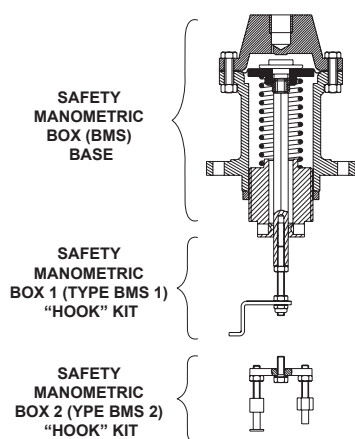

Figure 19. Type BMS 1 Max. - Min.

Table 10. Detection Configurations

		Actioner	Max. only	Min. only	Max. & Min.
One BMS	BMS 1	Releasing screw	Active	Neutral	Active
		Hook	Neutral	Active	Active
Two BMS	BMS 1	Releasing screw	Active	----	----
		Hook	Neutral		
	BMS 2	Push button	Active	Neutral	Active
		Hook	Neutral	Active	Active



N16

Figure 20. BMS with Diaphragm

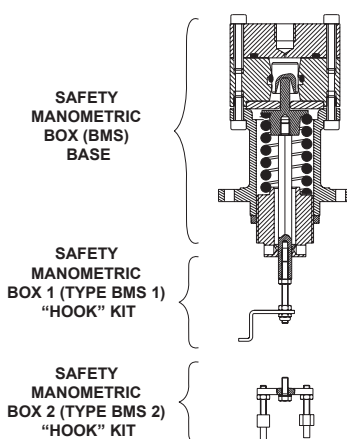

N17

Figure 21. BMS with Piston

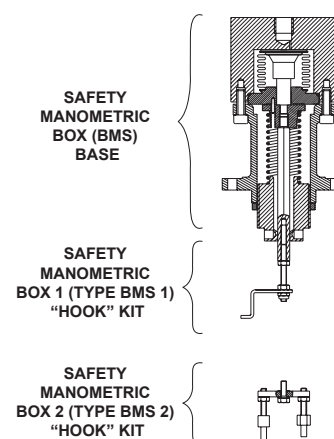

N18

Figure 22. BMS with Bellows

Table 11. Spare Parts

Description		Diaphragm (Max. and/or Min.)		Piston (Max. or Min.)		Bellows (Max. and/or Min.)	
		162	71	27	17	236	315
Type BMS 1	Complete box	FA181071X12	FA181072X12	FA180999X12	FA180998X12	FA181073X12	FA181074X12
	Base	FA181105T12	FA181106T12	FA181107T12	FA181108T12	FA181109T12	FA181110T12
	Hook kit	FA181111T12					
Type BMS 2	Complete box	FA181084X12	FA181085X12	FA181070X12	FA181069X12	FA181086X12	FA181087X12
	Base	FA181105T12	FA181106T12	FA181107T12	FA181108T12	FA181109T12	FA181110T12
	Hook kit	FA181112T12					
Spare Parts Kits	Diaphragm	FA137906X12	FA142549X12	----	----	----	----
	Set of O-rings	----		FA197352X12		----	

OPERATION (BMS)

The pressure of the network to be protected pushes the diaphragm, piston or bellows. The force resulting from this opposes the force (adjustable) coming from the setpoint spring. When pressure varies, the detection rod moves and provokes releasing by max. or min. pressure.

CONNECTIONS (BMS)

On the mechanism box: 2 H M6x16 screws (code FA402018X12)
 BM sealing: Flat O-ring and tight shut O-rings
 On the manometric box: 1/4" NPT screw
 Recommended tube: 8/10 mm

The sensing line must be connected downstream of the regulator.

Table 12. Max. Pressure Releasing

Pressure	Type BMS 1	Type BMS 2
	Releasing screw	Push button
Normal	Without D1 pin contact	Without D2 pin contact
Increase	With D1 pin contact	With D2 pin contact
= Setpoint	Rotation of releasing stem and 1st stage trigger	

Table 13. Min Pressure Releasing

Pressure	Type BMS 1	Type BMS 2
	Hook	Hook
Normal	Without D2 pin contact	Without D1 pin contact
Decrease	With D2 pin contact	With D1 pin contact
= Setpoint	Rotation of releasing stem and 1st stage trigger	

Type OS2

SPRING ADJUSTMENTS RANGES (BMS)

(See definitions table 17)

Table 14. Max. Only Spring Adjustment Ranges

	BMS			SPRING		MAX. ONLY			INTERVALS
	Type	Size	PMS box (bar)	ø Wire (mm)	Code	Wdso setting, bar			Δ1
						Max. low point possible	Recommended range		Δ1 (bar)
							Max. low point	Max. high. point	
MAX. ONLY	Diaphragm	162	10	2.0	FA113195X12	0.010	0.015	0.035	0.004
				2.5	FA113196X12	0.025	0.040	0.080	0.005
				3.0	FA113197X12	0.045	0.080	0.140	0.010
				3.5	FA113198X12	0.070	0.070	0.240	0.014
				4.0	FA113199X12	0.115	0.140	0.380	0.018
				5.0	FA113201X12	0.140	0.300	0.750	0.050
				5.5	FA113202X12	0.250	0.600	1.3	0.080
	071	20	4.5	FA113200X12	1.0	2.0	5.1	0.350	
			5.5	FA113202X12	2.1	4.0	11.0	0.700	
			6.5	FA114139X12	4.0	8.0	16.0	1.6	
	Piston	027	100	5.5	FA113202X12	16.0	16.0	22.0	3.0
				6.5	FA114139X12	22.0	22.0	40.0	6.5
		017	100	5.5	FA113202X12	40.0	40.0	55.0	7.0
6.5				FA114139X12	55.0	55.0	100.0	12.0	
Bellows	236	35	5.5	FA113202X12	5.5	11.0	22.0	1.6	
			6.5	FA114139X12	8.3	16.0	35.0	2.5	
	315	72	5.0	FA113201X12	17.5	35.0	72.0	5.0	

Table 15. Min. Only Spring Adjustment Ranges

	BMS			SPRING		MIN. ONLY			INTERVALS
	Type	Size	PMS box (bar)	ø Wire (mm)	Code	Wdso setting, bar			Δ1
						Min. low point possible	Recommended range		Δ1 (bar)
							Min. low point	Min. high. point	
MIN. ONLY	Diaphragm	162	10	2.0	FA113195X12	0.010	0.015	0.035	0.004
				2.5	FA113196X12	0.025	0.040	0.080	0.005
				3.0	FA113197X12	0.045	0.080	0.150	0.010
				3.5	FA113198X12	0.070	0.070	0.240	0.014
				4.0	FA113199X12	0.115	0.150	0.400	0.018
				5.0	FA113201X12	0.140	0.300	0.650	0.050
				5.5	FA113202X12	0.250	0.600	1.15	0.080
	071	20	4.5	FA113200X12	1.0	2.0	4.7	0.350	
			5.5	FA113202X12	2.1	4.0	9.5	0.700	
			6.5	FA114139X12	4.0	8.0	14.4	1.6	
	Piston	027	100	5.5	FA113202X12	16.0	16.0	19.0	3.0
				6.5	FA114139X12	19.0	19.0	38.0	6.5
		017	100	5.5	FA113202X12	38.0	38.0	50.0	7.0
6.5				FA114139X12	50.0	50.0	90.0	12.0	
Bellows	236	35	5.5	FA113202X12	5.5	11.0	16.0	1.6	
			6.5	FA114139X12	8.3	16.0	28.0	2.5	
	315	72	5.0	FA113201X12	17.5	28.0	65.0	5.0	

Table 16. Max. and Min. Spring Adjustment Ranges

MAX. AND MIN.	BMS			SPRING		MAX. and MIN.		INTERVALS $\Delta 1$ and $\Delta 2$		
	Type	Size	PMS box (bar)	\varnothing Wire (mm)	Code	Wdsu setting (bar)		$\Delta 1$ (bar)	$\Delta 2$ (bar)	
						Min. low point possible	Max. high point			
	Diaphragm	162	10	2.0	FA113195X12	0.010	0.035	0.004	0.010	
				2.5	FA113196X12	0.025	0.080	0.005	0.025	
				3.0	FA113197X12	0.045	0.140	0.010	0.050	
				3.5	FA113198X12	0.070	0.240	0.014	0.060	
				4.0	FA113199X12	0.115	0.380	0.018	0.150	
				5.0	FA113201X12	0.140	0.750	0.050	0.350	
				5.5	FA113202X12	0.230	1.3	0.080	0.600	
				6.5	FA114139X12	0.450	2.3	0.170	1.1	
				071	20	4.5	FA113200X12	1.0	5.1	0.350
	5.5	FA113202X12	2.1			11.0	0.700	5.5		
	6.5	FA114139X12	4.0			16.0	1.6	10.0		
	Piston	027	Not possible with only 1 BMS							
		017								
Bellows	236	35	5.5	FA113202X12	5.5	16.0	1.6	10.0		
			6.5	FA114139X12	8.3	28.0	2.5	20.0		
	315	72	5.0	FA113201X12	17.5	65.0	5.0	33.0		

Definitions

Table 17. Definitions

PSD box	Maximum operating pressure for box
Pd	Nominal downstream regulator pressure
Pd max	Maximum downstream regulator pressure (normally closing regulator pressure)
Pd min	Minimum downstream regulator pressure (disturbance in function with flow and/or inlet pressure is to be considered)
Pdo	Maximum releasing pressure
Max. high point	High regulator pressure at maximum
Max. low point	Low regulator pressure at maximum remaining within the accuracy class
Max. low point possible	Low regulator pressure at furthest maximum point (precision is not guaranteed)
Pdu	Minimum releasing pressure
Min. high point	High minimum regulator pressure
Min. low point	Low regulator pressure at minimum remaining within the accuracy class
Min. low point possible	Low regulator pressure at furthest minimum point (precision is not guaranteed)
Wdso	Overpressure specific range obtained from slam shut valve
Wdsu	Underpressure specific range obtained from slam shut valve
$\Delta 1$	Minimum difference allowed between Pdo and Pd max. and/or between Pdu and Pd min.
$\Delta 2$	Maximum difference allowed between maximum and minimum releasing pressure

Type OS2

Selection Guide Lines: Pressure Limitations

Table 18. Pressure Limitations

Max. Only	Min. Only	Max. and Min.
$Pdo \leq PSD \text{ box (BMS)}$	$Pd \text{ max} < PSD \text{ box (BMS)}$	$Pdo \leq PSD \text{ Box (BMS)}$
$Pdo \leq Pt \text{ high point}$	$Pdu \leq Pt \text{ high point}$	$Pdo \leq Pt \text{ high point}$
$Pdo \geq Pt \text{ low point}$	$Pdu \geq Pt \text{ low point}$	$Pdo \geq Pd \text{ max} + \Delta 1$
$Pdo \geq Pd \text{ max} + \Delta 1$	$Pdu \geq Pd \text{ min} - \Delta 1$	$Pdu \geq Pt \text{ lowest point possible}$
		$Pdu \leq Pd \text{ min} - \Delta 1$
		$Pdo - Pdu \leq \Delta 2$

Note

When the setpoint (max. or min.) falls between the lowest and lowest point possible, the precision may pass into a superior range (example AG 2.5 → AG 5). If the point value is too close to that of the Pd, the option RJGI tripping is recommended (consult factory). In the case of two safety manometric boxes (BMS) both boxes should have a PSD > to the highest Pdo.

Selection of BMS and Springs

Choose the type of safety manometric box (BMS) according to: PMS, the type of releasing precision.

Choice of springs:

- **Max. or Min. only**
Take the spring with the highest point directly superior to the releasing pressure required.
- **Max. and Min.**
Take the spring with the highest maximum point superior to the maximum releasing pressure required or with the lowest point inferior to the minimum tripping pressure required.

Table 19. Choice of BMS and Springs

PSD	Diaphragm	Bellows	Piston
0 to 20			
20 to 72		(*)	
72 to 100			
AG 2.5			
AG 5			
Max. only			
Min. only			
Max. and Min.			

(*) Choice between piston (regular) and bellows (optional). Bellows are recommended if you require a small gap between releasing pressure, inlet pressure and exact precision. Pistons do not facilitate minimum and maximum releasing.

MATERIALS (BMS)

Table 20. BMS Material

	Diaphragm	Bellows	Piston
Spring case	Zinc-plated steel		Stainless steel
Spring box	Aluminum + Chromatisation		
Diaphragm	Nitrile mesh		
Piston			Stainless steel
Bellows		Stainless steel	
Spring	Zinc-plated steel		
Adjustment screw	Zinc-plated steel		

ADJUSTMENT (BMS)



WARNING

AUTHORIZED PERSONNEL ONLY

Risk of injury

After rearming, remove the reset key from the stem. Do not put fingers in or near the reset mechanism area.

Generally speaking, adjustments are carried out with the slam shut valve closed. Only the detection stage is reset. Control of the releasing value may be obtained by resetting the two stages.



CAUTION

Before any adjustment, check that the spring range installed corresponds to the required setpoint.

Type BMS 1 (Figures 20 to 22)

Releasing by Max. Only

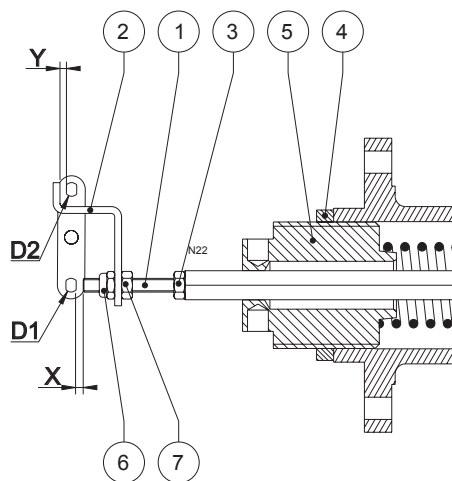

X = distance between releasing screw and pin D1
Y = distance between releasing screw and pin D2

Figure 23. Releasing by Max. Only

• Adjusting the Releasing Screw

- Free the min. hook (key 2), then in the following conditions:
 - no pressure in the safety manometric box (BMS)
 - setpoint spring compressed so that the distance between the releasing screw and the pin D1 no longer increases
- Adjust the releasing screw (key 1) to X = 1.5 mm (detection stage set)
- Jam nut (key 3)

• Adjusting the Max. Only Releasing Pressure

- Admit the releasing pressure to Pdo
- Screw the adjustment screw (key 5) until detection stage can be set
- Unscrew the adjustment screw (key 5) until detection stage release
- Check the pressure value at the releasing point (adjust if necessary)
- Jam nut (key 4)

Releasing by Min. Only

• Adjusting the Releasing Screw and Hook

- Free the min. hook (key 2), then in the following conditions:
 - setpoint spring decompressed (adjustment screw (key 5) unscrewed)

- pressure equal to the releasing pressure required for Pd min in the BMS

- Adjust the releasing screw (key 1) to X = 2 mm (detection stage set)
- Jam nut (key 3)
- Put the hook (key 2) into position and adjust Y = 1.5 mm with nuts (key 6) and (key 7)
- Jam nuts (key 6) and (key 7).

• Adjusting the Min. Only Releasing Pressure

- Continue admitting the required releasing pressure. Screw the adjustment screw (key 5) until detection stage release.
- Check the pressure value at the releasing point (adjust if necessary).
- Jam lock nut (key 4).

Releasing by Max. and Min. (Diaphragm or Bellows Only)

• Adjusting the Releasing Screw

- Free the min. hook (key 2), then in the following conditions:
 - setpoint spring decompressed (adjustment screw (key 5) unscrewed),
 - pressure equal to the max. releasing pressure required in the BMS,
- adjust the releasing screw (key 1) to X = 0 mm (detection stage set).
- Release manually.
- Unscrew the releasing screw (key 1) 2 turns, which represents a distance of approximately 1.5 mm.
- Jam nut (key 3).

• Max. Adjustment

- Same procedure as paragraph "Adjusting max. only releasing pressure"

• Min. Adjustment

- Admit an average pressure between max. and min., (for example: regulator set-point pressure)
- Set the slam shut
- Admit a pressure equal to the min. Pd min. releasing pressure required
- Adjust the hook (key 2) by progressively moving nuts (key 6) and (key 7) until it releases
- Jam nuts (key 6) and (key 7)
- Check the pressure value at the releasing point (adjust if necessary).

Type OS2

Type BMS 2 with 1 Max. Only Type BMS 1

Releasing by Max. Only

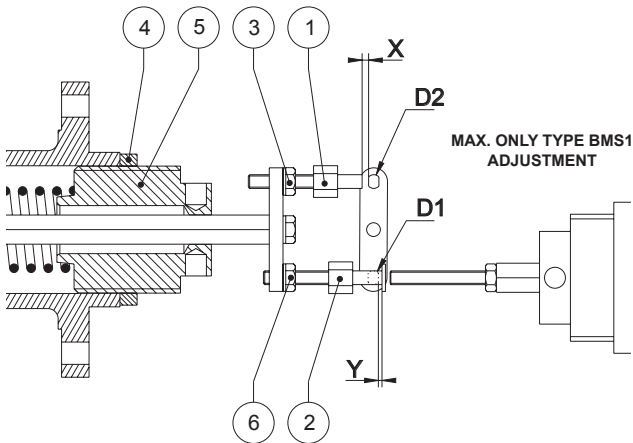

Figure 24. BMS 2 - Releasing by Max. Only

• Adjusting the Max. Push Button

- Remove the hook (key 2), then in the following conditions:
 - no pressure in the BMS
 - setpoint spring compressed so that the distance between the push button (key 1) and the pin D2 no longer increases
- Adjust the push button (key 1) to $X = 1.5$ mm (detection stage set)
- Jam nut (key 3).

• Adjusting the Max. Only Releasing Pressure

- Same procedure as paragraph "Adjusting the max. only releasing pressure".

Releasing by Min. Only

• Adjusting the Min. Only Releasing Pressure

- Remove the max. push button (key 1) or screw it tight to neutralize it
- Jam nut (key 3), then in the following conditions:
 - setpoint spring decompressed (adjustment screw (key 5) unscrewed)
 - pressure equal to releasing pressure required in the BMS, adjust the min. hook (key 2) to $Y = 1.5$ mm (detection stage set)
- Jam nut (key 6).

• Adjusting the Min. Only Releasing Pressure

- Same procedure as paragraph "Adjusting max. only releasing pressure".

Releasing by Max. and Min.

• Adjusting the Push Button

- The min. hook (key 2) is completely unscrewed, then in the following conditions:
 - setpoint spring decompressed (adjustment screw (key 5) unscrewed),
 - pressure equal to the max. releasing pressure required in the BMS
- Adjust the push button (key 1) to $X = 0$ mm (detection stage set)
- Release manually
- Unscrew the push button (key 1) 2 turns, which represents a distance of approximately 1.5 mm
- Jam nut (key 3).

• Adjusting the Releasing Pressure to Max. and Min

- **Max. Adjustment**
 - Same procedure as paragraph "Adjusting the max. only releasing pressure".
- **Min. Adjustment**
 - Admit an average pressure between max. and min., (for example regulator set-point pressure)
 - Set the detection stage
 - Admit a pressure equal to the min. releasing pressure required
 - Screw the hook (key 2) progressively until detection stage release
 - Jam nut (key 6)
 - Check the pressure value at the releasing point (adjust if necessary).

MAINTENANCE (BMS)

• Control

The safety valve and pressure accessories are subject to normal wear and must be inspected periodically and replaced if necessary.

- Slam shut releasing
- External tight shut
- Impulse part (diaphragm, bellows or piston)

The frequency of inspections, checks and replacement depends on the severity of service conditions and must comply with the national or industrial codes, standards and regulations/ recommendations applicable.

• Disassembly

- Unscrew the connector from the sensing line
- Remove the safety manometric box (BMS)
- Unscrew the blocking nut on the adjustment screw (manually)

- Unscrew the adjustment screw (resetting tool)
- Remove the hook or plate, depending on the type of Type BMS 1 or 2, from the detection rod (flat spanner 7)
- Remove the upper case
 - BMS 162 (flat spanner 11)
 - BMS 071 (flat spanner 8)
 - BMS piston 27/17 (key 5)
 - BMS bellows 236/315 (key 5)
- Disassemble the set plate/counter plate (flat spanner 17 and pliers) or
- Remove the bellows or piston and guide (manually)
- **Assembly**
 - Proceed in reverse order to disassembly
- **BMS torque values**
 - Upper spring case/manometric box
 - BMS 162: 8 N•m
 - BMS 071: 5 N•m
 - BMS piston 27/17: 6 N•m
 - BMS bellows 236/315: 6 N•m
 - BMS 162 and 071 nut/diaphragm plate: 20 N•m

Type OS2

 Webadmin.Regulators@emerson.com

 [Fisher.com](#)

 Facebook.com/EmersonAutomationSolutions

 LinkedIn.com/company/emerson-automation-solutions

 Twitter.com/emr_automation

Emerson Automation Solutions

Americas

McKinney, Texas 75070 USA
T +1 800 558 5853
+1 972 548 3574

Europe

Bologna 40013, Italy
T +39 051 419 0611

Asia Pacific

Singapore 128461, Singapore
T +65 6770 8337

Middle East and Africa

Dubai, United Arab Emirates
T +971 4 811 8100

*Francel SAS, 3 Avenue Victor Hugo, CS 80125, Chartres 28008, France
SIRET 552 068 637 00057 APE 2651B, N° TVA : FR84552068637, RCS Chartres B 552 068 637,
SAS capital 534 400 Euro*

D103683X012 © 2017 Emerson Process Management Regulator Technologies, Inc. All rights reserved. 06/17.

The Emerson logo is a trademark and service mark of Emerson Electric Co. All other marks are the property of their prospective owners. Fisher™ is a mark owned by Fisher Controls International LLC, a business of Emerson Automation Solutions.

The contents of this publication are presented for information purposes only, and while effort has been made to ensure their accuracy, they are not to be construed as warranties or guarantees, express or implied, regarding the products or services described herein or their use or applicability. All sales are governed by our terms and conditions, which are available on request. We reserve the right to modify or improve the designs or specifications of our products at any time without notice.

Emerson Process Management Regulator Technologies, Inc does not assume responsibility for the selection, use or maintenance of any product. Responsibility for proper selection, use and maintenance of any Emerson Process Management Regulator Technologies, Inc. product remains solely with the purchaser.

