

May 2018

CSB700 Series Commercial / Industrial Pressure Reducing Regulators



TYPE CSB704: CSB700 SERIES WITH TYPE VSX8 SLAM-SHUT

Figure 1. Typical CSB700 Series Pressure Reducing Regulator

Features and Benefits

- **Ductile Iron and WCC Steel Bodies Available**
- **Wide Variety of Body Sizes and End Connections**
- **With Type VSX8 Slam-shut Option**
- **No Special Tools for Pressure Adjustment and Orifice Removal**

Introduction

The CSB700 Series direct-operated, spring-loaded regulators have been engineered to fit a multitude of pressure reducing applications including commercial and industrial installations. This flexibility is provided by the numerous body sizes and end connections, outlet pressure settings. In addition to application flexibility, CSB700 Series offers multiple overpressure protection options to meet your application requirements.

CSB700 Series

Specifications

The Specifications section lists the specifications for the CSB700 Series regulators. The following information is stamped on the nameplate of CSB700 Series: Type and Class, Maximum Outlet Pressure and Spring Range.

Available Configurations

See Table 1

Body Sizes, Materials, End Connections and Pressure Ratings⁽¹⁾

See Table 2

Inlet Pressure Ratings⁽¹⁾

See Tables 3 and 4

Maximum Outlet Pressure⁽¹⁾

Emergency Casing:

Type CSB700/CSB700F/CSB720/CSB720F:

4.0 bar / 58.0 psig

Type CSB750: 5.0 bar / 72.5 psig

To Avoid Internal Metallic Parts Damage:

Type CSB700/CSB700F/CSB720/CSB720F:

0.34 bar / 5.0 psig over set pressure

Type CSB750: 1.5 bar / 21.8 psig over set pressure — not to exceed maximum emergency outlet

Operating Casing:

Type CSB700/CSB720: 1.1 bar / 16 psig

Type CSB750: 5.0 bar / 72.5 psig

Outlet Pressure Ranges⁽¹⁾

9.0 mbar to 4.0 bar / 0.13 to 58.0 psig

See Table 5

Flow Capacities

See Tables 7 through 40

Orifice Size

35 mm / 1-3/8 in.

Flow and IEC Sizing Coefficients

See Table 4

Temperature Capabilities⁽¹⁾⁽²⁾⁽³⁾

According to PED Standards:

-20 to 66°C / -4 to 151°F

Non-PED:

-30 to 66°C / -22 to 151°F

Spring Case Vent Connection

1 NPT: Types CSB700 and CSB720

1/2 NPT: Type CSB750

Spring Case Vent and Body Orientation

See Figure 5

Type VSX8 Slam-Shut Device Maximum Inlet Pressure (P_{umax})⁽¹⁾:

Differential Strength (DS): 16 bar / 232 psig

Integral Strength (IS): 6.0 bar / 87 psig

Construction Materials

CSB700 Series Main Valve and Actuator

Body: Ductile iron or WCC Steel

Body O-ring: Nitrile (NBR)

Closing Cap: Aluminum

Adjusting Screw: Aluminum

Adjusting Bolt: Steel

Spring Case, Lower Casing and

Valve Stem: Aluminum

Orifice: Aluminum

Pusher Post and Relief Valve Seat: Aluminum

Diaphragm and Disk: Nitrile (NBR)

Control Spring: Music wire or Stainless steel

Relief Valve Spring: Stainless steel

Relief Valve Diaphragm Retainer: Zinc-plated steel

Retainer Ring: Zinc-plated steel

Lever Pin: Carbon steel

Lever: Steel Spring Seat and other metal parts:

Zinc-plated steel

Type VSX8 Slam-shut Device

Diaphragm Case, Spring Case

and Valve Stem: Aluminum

Diaphragm Plate: Stainless steel or

Noryl™ GFN2 Plastic

Diaphragm and Disk: Nitrile (NBR)

Control Spring: Steel

Vent Screen: 18-8 Stainless steel

Vent Screen Retainer: Zinc-plated steel

Closing Cap: Aluminum

Adjusting Screw: Leaded-Brass

Approximate Weights

with Threaded body

Type CSB700/CSB720: 13 kg / 29 lbs

Type CSB750: 14 kg / 31 lbs

Type CSB704/CSB724: 14 kg / 31 lbs

Type CSB754: 15 kg / 33 lbs

with Flanged body

Add 5.2 kg / 11 lbs to weights listed

Designed, Tested and Evaluated Consistent With:

ANSI B16, ASME BPVC Section VIII Division I,

ASTM B117 (Corrosion Resistance), EN 334 and

EN 14382

1. The pressure/temperature limits in this Bulletin or any applicable standard limitation should not be exceeded.

2. Standard token relief set values listed in Tables 6a, 6b, 6c and 6d are based on -20 to 60°C / -4 to 140°F.

3. Product has passed Emerson Process Management Regulator Technologies, Inc. testing for lockup, relief start-to-discharge and reseal down to -40°.

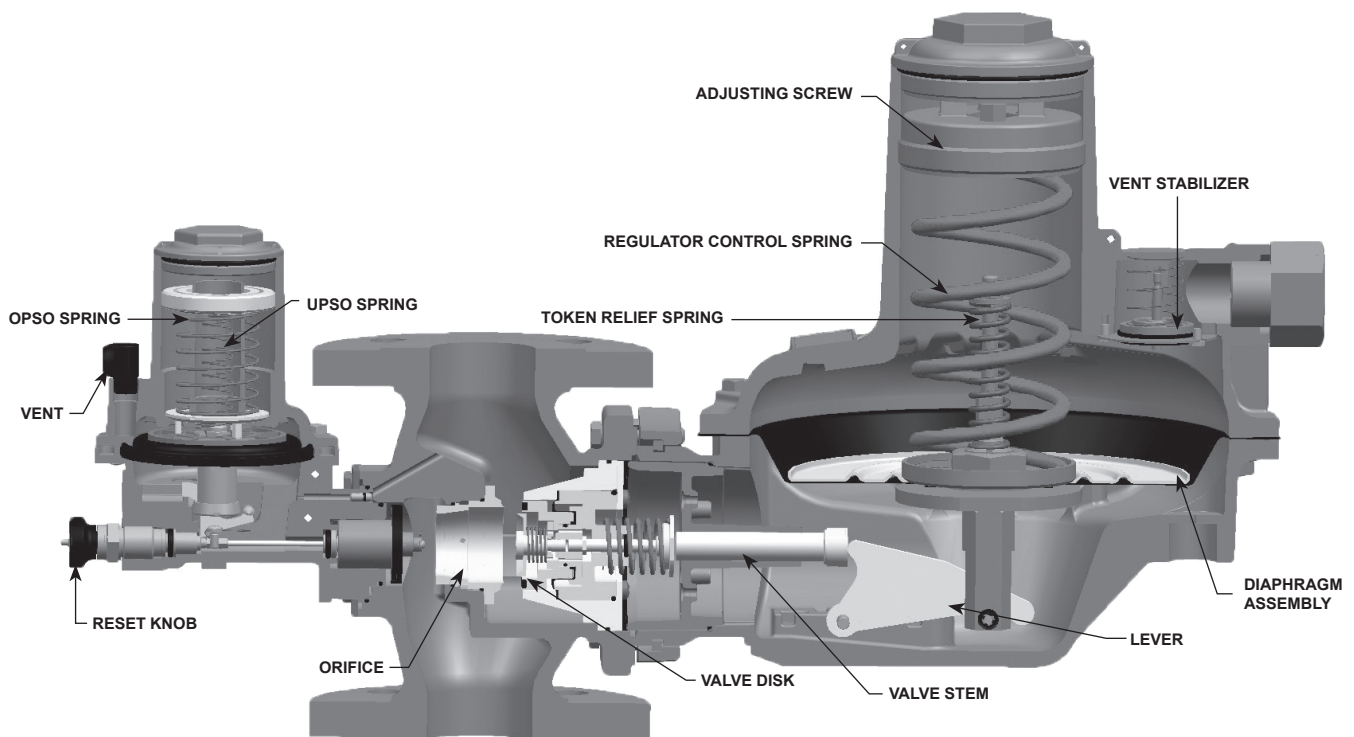

Figure 2. Type CSB704 Regulator with Type VSX8 Slam-Shut Internal View

Multiple Overpressure Protection Options Available:

- **Token Internal Relief** – Provides relief from minor overpressure caused by nicks or dents on the orifice or by thermal expansion of gas in the downstream line. Token relief also provides a token or signal, in the form of odor, indicating that an overpressure situation is occurring.
- **Slam-Shut Protection** – Discontinues gas service by shutting off the gas flow if there is an overpressure or underpressure condition.

Principle of Operations

Refer to Figures 3 and 4. When downstream demand decreases, the pressure under the diaphragm increases. This pressure overcomes the regulator setting (which is set by a spring). The action of the pusher post assembly, lever, and valve stem moves the balanced port assembly closer to the orifice and reduces gas flow. If downstream demand increases, pressure under the diaphragm decreases. Spring force pushes the pusher post assembly downward and the balanced port assembly moves away from the orifice.

Installation

The CSB700 Series regulators may be installed in any position. As long as the flow through the body is the same as indicated by the flow direction arrow on the body and the spring case vent is pointed downward (see Figure 5). If gas escaping through the CSB700 Series token internal relief valve could constitute a hazard, the spring case vent must be piped to a location where escaping gas will not be hazardous. If the vented gas will be piped to another location, install obstruction-free tubing or piping at least equal to the vent and the end of the vent pipe must be protected from anything that might clog it.

Downstream Control Line Connection

A CSB700 Series regulator with an “ET” or “EN” in the type number has a blocked throat, an O-ring stem seal and a 3/4 NPT control line tapping in the lower diaphragm casing, Figure 4. A regulator with a downstream control line is typically used for monitoring installations or other applications where there is an equipment installed between the regulator and the pressure control point. The O-ring stem seal helps separate body pressure from diaphragm case pressure on monitor installations where leakage cannot be tolerated. Refer to the CSB700 Series Instruction Manual for instructions on downstream control line installation.

CSB700 Series

Table 1. Available Configurations

TYPE NUMBER					OPTION	
C	S	B	7			
						PRESSURE CONSTRUCTION
	0					Low Pressure Applications (Outlet Pressure: 9.0 to 110 mbar / 3.6 in. w.c. to 1.6 psig) ⁽²⁾
	2					Medium Pressure Applications (Outlet Pressure: 61 to 780 mbar / 0.9 to 11.3 psig) ⁽²⁾
	5					High Pressure Applications (Outlet Pressure: 0.70 to 4.0 bar / 10.2 to 58.0 psig) ⁽²⁾
						OVERPRESSURE PROTECTION
	0					Without Overpressure Protection Module
	0F					Without Overpressure Protection Module (Outlet Pressure: 9.0 to 110 mbar / 3.6 in. w.c. to 1.6 psig and 270 to 325 mbar / 3.9 to 4.7 psig only) ⁽²⁾
	4					With Type VSX8 Slam-shut Module ⁽¹⁾
	4F					With Type VSX8 Slam-shut Module ⁽¹⁾ (Outlet Pressure: 9.0 to 110 mbar / 3.6 in. w.c. to 1.6 psig and 270 to 325 mbar / 3.9 to 4.7 psig only) ⁽²⁾
						PRESSURE REGISTRATION
				E		External
						RELIEF
				N		None
				T		Token Internal Relief ⁽³⁾
Example: Type number CSB724ET: Type CSB700 regulator constructed for medium pressure applications, with Type VSX8 Slam-shut Module, with External pressure registration and with Token relief.						
1. Reference Instruction Manual D103127X012 for information regarding the Type VSX8 Slam-shut Module.						
2. The pressure/temperature limits in this Bulletin and any applicable standard or code limitation should not be exceeded.						
3. Token relief not available for outlet pressure above 500 mbar / 8 psig.						

Table 2. Body Sizes, Material, End Connections and Cold Working Pressure Ratings

BODY MATERIAL	BODY SIZE		END CONNECTION	FACE-TO-FACE DIMENSION		BODY PRESSURE RATING	
	DN	NPS		mm	In.	bar	psig
Ductile Iron	40	1-1/2	NPT	155	6.10	17.2	250
	50	2					
	40	1-1/2	Rp	191	7.52		
	50	2					
	50	2	CL125 FF/CL150 FF	254	10.0		
	50	2		267	10.5		
	50	2		191	7.52		
	50	2	PN 10/16	200	7.87	16.0	232
	50	2		254	10.0		
	40	1-1/2	PN 16 Slip-On	222	8.74		
WCC Steel	40	1-1/2	NPT	155	6.10	20.0	290
	50	2					
	40	1-1/2	Rp	254	10.0		
	50	2					
	50	2	CL150 RF	191	7.52	16.0	232
	50	2	PN 10/16				
	50	2	PN 10/16				

Table 3. Integral Strength (IS) Pressure Ratings⁽¹⁾

TYPE	MAXIMUM ALLOWABLE PRESSURE / MAXIMUM EMERGENCY INLET PRESSURE		MAXIMUM OPERATING INLET PRESSURE ⁽²⁾	
	P_s		P_{umax}	
	bar	psig	bar	psig
CSB700 and CSB704	4.0	58.0	4.0	58.0
CSB700F and CSB704F				
CSB720 and CSB724				
CSB720F and CSB724F				
CSB750 and CSB754	5.0	72.5	5.0	72.5

1. Applicable only to applications where the inlet rating cannot exceed the outlet rating.
2. For the Integral Strength (IS version), the maximum value of P_s and P_{umax} should be similar to the PSD used for the Differential Strength (DS) version.

Table 4. Differential Strength (DS) Pressure Ratings and Flow and Sizing Coefficients

TYPE	SPECIFIC MAXIMUM ALLOWABLE PRESSURE / MAXIMUM EMERGENCY OUTLET PRESSURE ⁽¹⁾		MAXIMUM ALLOWABLE PRESSURE / MAXIMUM EMERGENCY INLET PRESSURE ⁽¹⁾		MAXIMUM OPERATING INLET PRESSURE ⁽¹⁾		ORIFICE SIZE		WIDE-OPEN FLOW COEFFICIENT			IEC SIZING COEFFICIENT		
	P_{sd}		P_s		P_{umax}		mm	In.	C_g	C_v	C_i	X_T	F_D	F_L
	bar	psig	bar	psig	bar	psig								
CSB700 and CSB704	4.0	58.0	12.0	174	10.0	145	35	1-3/8	1080	27.7	39	0.96	0.89	0.66
CSB700F and CSB704F					6.0	87								
CSB720F and CSB724F					16	232								
CSB720 and CSB724														
CSB750 and CSB754	5.0	72.5	20.0	290	16	232								

1. The pressure/temperature limits in this Bulletin and any applicable standard or code limitation should not be exceeded.

Table 5. CSB700 Series Primary Regulator Outlet Pressure Ranges

TYPE	OPERATING PRESSURE RANGES, W_d		PART NUMBER	SPRING COLOR	SPRING WIRE DIAMETER		SPRING FREE LENGTH	
	mbar	psig			mm	In.	mm	In.
CSB700, CSB704, CSB700F and CSB704F	9 to 14	3.6 to 5.6 in. w.c.	GE30336X012	Silver	3.00	0.118	224	8.82
	13 to 24	5.2 to 9.6 in. w.c.	ERSA01138A0	Red	3.50	0.138	264	10.4
	22 to 39	8.8 to 15.7 in. w.c.	GE30338X012	Black Stripe	4.32	0.170	172	6.78
	32 to 50	12.8 to 20.1 in. w.c.	GE30339X012	Purple	4.34	0.171	187	7.35
	42 to 70	16.9 to 28.1 in. w.c.	GE30340X012	White Stripe	4.62	0.182	188	7.40
CSB720 and CSB724	61 to 110	0.9 to 1.6	ERSA03656A0	Dark Green	4.88	0.192	224	8.82
	61 to 110	0.9 to 1.6	ERSA03656A0	Dark Green	4.88	0.192	224	8.82
	105 to 220	1.5 to 3.2	ERSA03657A0	Blue	5.94	0.234	217	8.53
	210 to 380	3.1 to 5.5	GG06247X012	Black	8.00	0.315	206	8.13
	320 to 570	4.6 to 8.3	ERSA01582A0	Red with White Stripe	8.71	0.343	177	6.97
CSB720F and CSB724F	270 to 325	3.9 to 4.7	ERAA11747A0	Blue with White Stripe	10	0.394	181	7.13
CSB750 and CSB754	270 to 325	3.9 to 4.7	ERAA11747A0	Black with White Stripe	6.5	0.256	235	9.25
	0.7 to 1.19 bar	10.2 to 17.3	GE30345X012	Purple Stripe	9.00	0.354	225	8.87
	1.05 to 2.7 bar	15.2 to 39.2	GE30346X012	Brown	11.0	0.433	226	8.88
	2.3 to 3.25 bar	33.4 to 47.1	ERSA01125A0	Grey with Red Stripe	12.6	0.496	225	8.87
	3.1 to 4 bar	45 to 58	ERSA01126A0	Grey with Orange Stripe	13.7	0.539	226	8.89

CSB700 Series

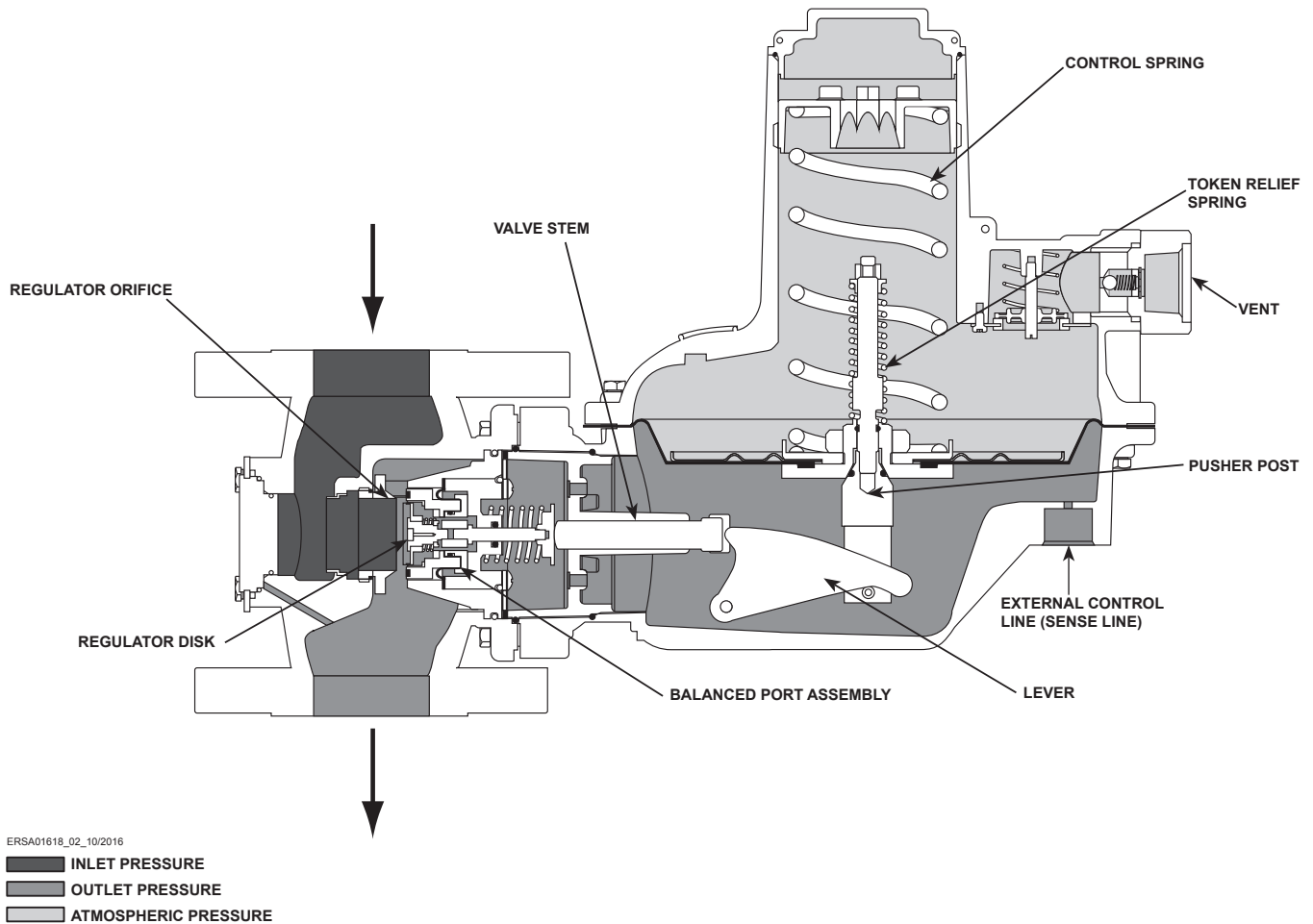

Figure 3. CSB700 Series with External Registration Operational Schematics

Internal Token Relief

CSB700 Series regulators with a “T” in the type number, provide a low capacity or token internal relief to help minimize overpressure. The token relief also acts to avoid nuisance trips of the slam-shut mechanism due to pressure increase from thermal expansion or overpressure caused by orifice damage such as nicks and dents.

Overpressure Protection

Overpressuring any portion of a regulator or associated equipment may cause personal injury, leakage or property damage due to bursting of pressure-containing parts or explosion of accumulated gas. Provide appropriate pressure relieving to ensure that the critical limits in the Specifications section are not exceeded. Regulator operation within ratings does not preclude the possibility of damage from external sources or from debris in the pipeline.

The CSB700 Series regulators have outlet pressure ratings that are lower than their inlet pressure ratings. A pressure-relieving or pressure-limiting device is needed for the CSB700 Series that do not have a slam-shut device installed.

Types CSB704, CSB724F, CSB724 and CSB754 regulators rely on Type VSX8 slam-shut device for overpressure protection. In the event that outlet pressure rises above or falls below the pressure setting of the Type VSX8, the slam-shut device will activate or trip, thereby stopping flow through to the downstream system. To restart flow to the downstream system, the Type VSX8 must be reset.

Type CSB704 regulators with a “T” in their type number provide a low capacity (Token) internal relief which provides sufficient relief to preclude the Type VSX8 tripping due to pressure rise caused by thermal expansion or overpressure due to orifice damage such as nicks and dents.

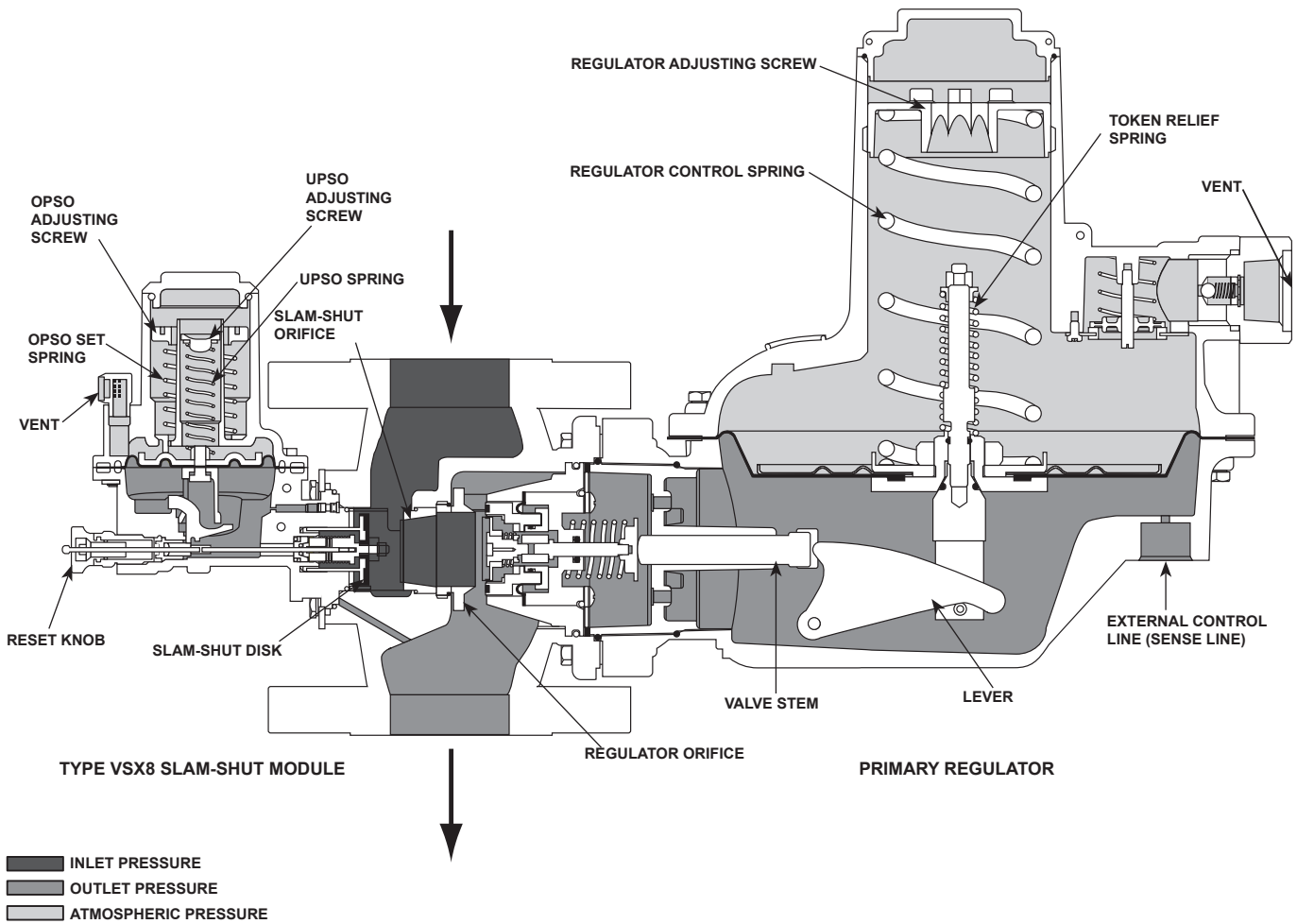

Figure 4. Type CSB704ET, Externally Registered Regulator and Slam-Shut Operational Schematic

Type VSX8 Slam-Shut Device

The Type VSX8 slam-shut device on the Type CSB704 regulator is a fast-acting shutoff device that provides overpressure (OPSO) or over and underpressure (OPSO/UPSO) protection by shutting off the flow of gas to the downstream system. The Type VSX8's actions are independent of the Type CSB704 regulator and of variations to the inlet pressure. The Type VSX8 uses external pressure registration and requires a downstream control line regardless if the regulator is internally or externally registered. Refer to the CSB700 Series Instruction Manual for instructions regarding downstream control line installation.

Refer to Figure 4, shutoff disk is normally located in the open (reset) position. If the pressure below the diaphragm increases (or decreases) reaching the Type VSX8 setpoint, the diaphragm will travel upwards (or downwards) to release the trip mechanism which allows the spring force on the stem to push the stem and disk against the seat, shutting off all gas flow. The manual reset has an internal bypass to equalize the reset pressure on either side on the shutoff disk.

Note

In order for the Underpressure Shutoff (UPSO) of any slam-shut to be triggered, the downstream pipe pressure must drop below the UPSO setpoint. In the case of a downstream line break, numerous factors can prevent the downstream pipe pressure from decreasing below the slam-shut UPSO setpoint. These factors include the distance of pipe to the break, the diameter of the pipe, size of the break and the number of restrictions, such as valves, elbows and bends, downstream of the regulator and/or slam-shut device. Due to these factors additional protections should be installed to stop flow in the event of a line break.

CSB700 Series

Table 6a. North American Overpressure Shut-off OPSO Only Ranges

REGULATOR			SLAM SHUT DEVICE								
Type	Typical Setpoint	Spring Range	Type (Maximum Operating Inlet)	Token Relief Set	Relief Range Shown as a % of Regulator Setpoint		Required Difference Between Token Relief and OPSO	Over Pressure Shut-off (OPSO) Set Range	Factory Set OPSO		
	psig	psig		psig	min	max	psig	psig	psig		
CSB704F	7 in. w.c.	5.2 to 9.6 in. w.c.	VSX8L (125 psi)	12 in. wc	170	215	3.2 in. w.c	12 to 24 in. w.c.	22 in. w.c.		
	11 in. w.c.	8.8 to 15.7 in. w.c.		17 in. wc	150	160	4 in. w.c.	16 in. w.c. to 1.6 psig	25 in. w.c.		
	14 in. w.c.	12.8 to 20.0 in. w.c.		21 in. wc	150	160	4 in. w.c.	24 in. w.c. to 2.8 psig	1.1		
	1	24 in. w.c. to 1.6 psig		1.4	140	150	6.4 in. w.c	1.4 to 4.1	2		
CSB724F	2	1.5 to 3.2		VSX8L (232 psi)	2.6	130	140	0.6	2.0 to 7.3	3.5	
	3				3.8	125	140	0.6		5	
	5	3.1 to 5.5			6.2	125	140	0.7	3.2 to 11.0	7	
	10	7.4 to 11.3						5.8 to 13.3 ⁽¹⁾	12		
CSB704	7 in. w.c.	5.2 to 9.6 in. w.c.			VSX8L (232 psi)	12 in. wc	170	215	3.2 in. w.c	12 to 24 in. w.c.	22 in. w.c.
	11 in. w.c.	8.8 to 15.7 in. w.c.				17 in. wc	150	160	4 in. w.c.	16 in. w.c. to 1.6 psig	25 in. w.c.
	14 in. w.c.	12.8 to 20.0 in. w.c.	21 in. wc			150	160	4 in. w.c.	24 in. w.c. to 2.8 psig	1.1	
	1	24 in. w.c. to 1.6 psig	1.4			140	150	6.4 in. w.c	1.4 to 4.1	2	
CSB724	2	1.5 to 3.2	VSX8H (232 psi)			2.6	130	140	0.6	2.0 to 7.3	3.5
	3					3.8	125	140	0.6		5
	5	3.1 to 5.5		6.2		125	140	0.7	3.2 to 11.0	7	
	10	7.4 to 11.3					5.8 to 13.3 ⁽¹⁾	12			
CSB754	15	10.2 to 17.3							13.1 to 39.1 ⁽¹⁾	19	
	20	15.2 to 39.2							13.1 to 43.5	25	
	30							23.2 to 72.5 ⁽¹⁾	35		
	40								45		

Grey areas indicate that token relief is not available above 8 psig setpoint.

1. Max OPSO setpoint truncated to reflect maximum outlet pressure for spring range.

Table 6b. European Overpressure Shut-off OPSO Only Ranges

REGULATOR			SLAM SHUT DEVICE						
Type	Typical Setpoint	Spring Range	Type (Maximum Operating Inlet)	Token Relief Set	Relief Range Shown as a % of Regulator Setpoint		Required Difference Between Token Relief and OPSO	Over Pressure Shut-off (OPSO) Set Range	Factory Set OPSO
	mbar	mbar		mbar	min	max	mbar	mbar	mbar
CSB704F	10	9 to 14	VSX8L (8.6 bar)	17	170	215	8	30 to 60	32
	15	13 to 24		26	170	215	6		
	20	13 to 24		34	170	215	6		
	21			36	170	215	4		
	27	22 to 39		41	150	160	5	30 to 60	46
	30			45	150	160	10		
	35			53	150	160	10		
	50	42 to 70		70	140	158	16	60 to 193	90
	60			84	140	158	16		
75	98		130	140	20				
CSB704	10	9 to 14	VSX8L (16 bar)	17	170	215	8	30 to 60	40
	15	13 to 24		26	170	215	10		
	20	13 to 24		34	170	215	10		
	21			36	170	215	10		
	27	22 to 39		41	150	160	10	30 to 60	55
	30			45	150	160	10		
	35			53	150	160	10		
	50	42 to 70		70	140	158	16	60 to 193	90
	60			84	140	158	16		
75	98		130	140	20				
CSB724	100	61 to 110	VSX8L (16 bar)	130	130	140	20	60 to 193	170
	120	105 to 220		156	130	140	40	95 to 280	205
	150			195	130	140	40		
	160			208	130	140	40		
	200	105 to 220		250	125	140	50	138 to 500	330
	300	210 to 380		375	125	140	50	138 to 500	450
	500	320 to 570		625	125	140	60	221 to 760	700
	600	510 to 780					400 to 915 ⁽¹⁾	840	
	750						400 to 1100 ⁽¹⁾	1050	
CSB724F	300		270 to 325	VSX8L (8.6 bar)				138 to 500	450
	1000	700 to 1190	VSX8H (16 bar)				400 to 1450	1320	
	1200	1050 to 2700					900 to 3000	1600	
	1500						1600 to 4000 ⁽¹⁾	2400	
2000	1050 to 2700				1600 to 5000 ⁽¹⁾	3400			
3000	2300 to 3250					4400			
4000	3100 to 4000								

Grey areas indicate that token relief is not available above 500 mbar setpoint.

1. Max OPSO setpoint truncated to reflect maximum outlet pressure for spring range.

Table 6c. North American Overpressure and Underpressure Shut-off UPSO/OPSO Ranges

REGULATOR			SLAM SHUT DEVICE									
Type	Typical Setpoint	Spring Range	Type (Maximum Operating Inlet)	Token Relief Set	Relief Range Shown as a % of Regulator Setpoint		Required Difference Between Token Relief and OPSO	UPSO	OPSO	Factory Set		
					min	max		Set Range	Shut-off (OPSO) Set Range Over UPSO Setpoint	UPSO	Adjusted OPSO Range	OPSO
		psig	psig	psig	min	max	psig	psig	psig	psig	psig	
CSB704F	7 in. w.c.	5.2 to 9.6 in. w.c.	VSX8L (125 psi)	12 in. w.c.	170	215	3.2 in. w.c.	3 to 12 in. w.c.	16 to 29 in. w.c.	3 in. w.c.	19 in. w.c. to 1.2 psig	22 in. w.c.
	11 in. w.c.	8.8 to 15.7 in. w.c.		17 in. w.c.	150	160	4 in. w.c.			6 in. w.c.	22 in. w.c. to 1.3 psig	25 in. w.c.
	14 in. w.c.	12.8 to 20.0 in. w.c.		21 in. w.c.	150	160	4 in. w.c.	4 in. w.c. to 1.1 psig	20 in. w.c. to 1.8 psig	9 in. w.c.	1 to 2.1 psig	1.1
	1	24.0 in. w.c. to 1.6 psig		1.4	140	150	6.4 in. w.c.	10 in. w.c. to 2.3 psig	1.2 to 3.2	14 in. w.c.	1.7 to 3.7	2
CSB724	2	1.5 to 3.2	VSX8L (232 psi)	2.6	130	140	0.6	1.5 to 7.3	2.6 to 5.6	1	2.2 to 4.2	3.5
	3			3.8	125	140	0.6			2	4.6 to 7.6	5
	5	3.1 to 5.5		6.2	125	140	0.7	3	5.6 to 8.6	7		
	10	7.4 to 11.3					1.5 to 7.3	3.5 to 8.2	5	8.5 to 13.2	12	
							1.5 to 10.9	6.7 to 13.5	7	13.7 to 20.5	19	
CSB704	7 in. w.c.	5.2 to 9.6 in. w.c.	VSX8L (232 psi)	12 in. w.c.	170	215	3.2 in. w.c.	3 to 12 in. w.c.	18 to 30 in. w.c.	3 in. w.c.	21 in. w.c. to 1.2 psig	22 in. w.c.
	11 in. w.c.	8.8 to 15.7 in. w.c.		17 in. w.c.	150	160	4 in. w.c.			6 in. w.c.	24 in. w.c. to 1.3 psig	25 in. w.c.
	14 in. w.c.	12.8 to 20.0 in. w.c.		21 in. w.c.	150	160	4 in. w.c.	4 in. w.c. to 1.1 psig	25 in. w.c. to 1.9 psig	9 in. w.c.	1.2 to 2.2 psig	1.1
	1	24.0 in. w.c. to 1.6 psig		1.4	140	150	6.4 in. w.c.	10 in. w.c. to 2.3 psig	1.2 to 3.2	14 in. w.c.	1.7 to 3.7	2
CSB724	2	1.5 to 3.2	VSX8L (232 psi)	2.6	130	140	0.6	1.5 to 7.3	2.6 to 5.6	1	2.2 to 4.2	3.5
	3			3.8	125	140	0.6			2	4.6 to 7.6	5
	5	3.1 to 5.5		6.2	125	140	0.7	3	5.6 to 8.6	7		
	10	7.4 to 11.3					1.5 to 7.3	3.5 to 8.2	5	8.5 to 13.2	12	
							1.5 to 10.9	6.7 to 13.5	7	13.7 to 20.5	19	
CSB754	15	10.2 to 17.3	VSX8H (232 psi)				7.3 to 29.0	15.2 to 22.8	10	25.2 to 32.8	25	
	20	15.2 to 39.2							7.3 to 29.0	18.1 to 33.4	15	33.1 to 48.4
	30			40	33.4 to 55.1						20	38.1 to 53.4

Grey areas indicate that token relief is not available above 8 psig setpoint.

Table 6d. European Overpressure and Underpressure Shut-off UPSO/OPSO Ranges

REGULATOR			SLAM SHUT DEVICE												
Type	Typical Setpoint	Spring Range	Type (Maximum Operating Inlet)	Token Relief Set	Relief Range Shown as a % of Regulator Setpoint		Required Difference Between Token Relief and OPSO	UPSO	OPSO	Factory Set					
					min	max		Set Range	Shut-off (OPSO) Set Range Over UPSO Setpoint	UPSO	Adjusted OPSO Range	OPSO			
		mbar	mbar	mbar	min	max	mbar	mbar	mbar	mbar	mbar				
CSB704F	15	13 to 24	VSX8L (8.6 bar)	26	170	215	6	7 to 11	30 to 44	8	38 to 52	40			
	20	13 to 24		34	170	215	6	7 to 11	30 to 44	10	40 to 54	40			
	21	13 to 24		36	170	215	4	7 to 11	30 to 44	10	40 to 54	40			
	27	22 to 39		41	150	160	5	7 to 15	32 to 44	14	46 to 58	46			
	30	22 to 39		45	150	160	10	7 to 30	40 to 72	15	55 to 87	60			
	35	22 to 39		53	150	160	10	7 to 30	40 to 72	18	58 to 90	70			
	50	42 to 70		70	140	158	16	10 to 75	48 to 74	25	73 to 99	90			
	60			84	140	158	16		48 to 74	30	78 to 104	100			
	75	61 to 110		98	130	140	20	25 to 160	83 to 221	38	121 to 259	130			
	CSB704	15		13 to 24	VSX8L (16 bar)	26	170	215	6	7 to 30	40 to 55	8	48 to 63	50	
20		13 to 24	34	170		215	6	7 to 30	40 to 55	10	50 to 65	55			
21		13 to 24	36	170		215	4	7 to 30	40 to 55	10	50 to 65	55			
27		22 to 39	41	150		160	5	7 to 30	40 to 55	14	54 to 69	55			
30		22 to 39	45	150		160	10	7 to 30	45 to 76	15	60 to 91	60			
35			53	150		160	10	7 to 30	45 to 76	18	63 to 94	70			
50		42 to 70	70	140		158	16	10 to 75	50 to 80	25	75 to 105	90			
60			84	140		158	16		50 to 80	30	80 to 110	100			
75	61 to 110	98	130	140	20	25 to 160	83 to 221	38	121 to 259	130					
CSB724	100	61 to 110	VSX8L (16 bar)	130	130	140	20	25 to 160	83 to 221	50	133 to 271	170			
	120			156	130	140	40			60	143 to 281	205			
	150			195	130	140	40			75	158 to 296	250			
	160			208	130	140	40			80	163 to 301	265			
	200	105 to 220		250	125	140	50	100 to 500	114 to 261	100	214 to 361	330			
	300			375	125	140	50		179 to 386	150	329 to 536	450			
	500			625	125	140	60		241 to 565	250	491 to 815	700			
	600									100 to 500	241 to 565	300	541 to 865	840	
750	510 to 780							100 to 750	460 to 932	375	835 to 1120 ⁽¹⁾	1050			
CSB724F	300	270 to 325	VSX8L (8.6 bar)							100 to 500	179 to 386	200	379 to 586	400	
	CSB754 GrDF	1000	0.7 to 1.19 bar	VSX8L (16 bar)							100 to 500	460 to 932	750	1210 to 1682	1210
CSB754		1000	0.7 to 1.19 bar	VSX8H (16 bar)							100 to 500	460 to 932	500	960 to 1432	1320
		1200	1.05 to 2.7 bar								500 to 2000	1050 to 1570	600	1650 to 2170	1650
		1500			750	1800 to 2320	1900								
		2000	1000		2250 to 3300	2400									
3000	2.3 to 3.25 bar	1500	2750 to 3800	3400											
4000	3.1 to 4 bar							500 to 2800	2100 to 3750	2000	4100 to 5000 ⁽¹⁾	4400			

Grey areas indicate that token relief is not available above 500 mbar setpoint.

1. Max OPSO setpoint truncated to reflect maximum outlet pressure for spring range.

Example: If a non-standard setpoint is needed, see the following example for the proper use of Tables 6a, 6b, 6c and 6d. In this example, the non-standard regulator setpoint is 140 mbar / 2.0 psig. The minimum factory token relief set pressure is 130% of the non-standard setpoint. The resulting token relief set pressure is 183 mbar / 2.6 psig. The minimum factory OPSO and UPSO set pressures are 165% and 50% of the non-standard setpoint, respectively. The resulting minimum settings are: OPSO = 231 mbar / 3.4 psig and UPSO = 70 mbar / 1.0 psig.

CSB700 Series

Capacity Information

Tables 7 through 40 provide natural gas regulating capacities at selected inlet pressures and outlet pressure settings for the CSB700 Series, which includes configurations that include the slam-shut device. Flows are in Sm³/h (16°C and 1.01325 bar) and SCFH (60°F and 14.7 psia) of 0.6 specific gravity natural gas.

To determine equivalent capacities for air, propane, butane or nitrogen, multiply the capacity value in the tables by the following appropriate conversion factor: 0.775 for air, 0.628 for propane, 0.548 for butane or 0.789 for nitrogen. For gases of other specific gravities, multiply the given capacity by 0.775 and divide by the square root of the appropriate specific gravity.

The published capacities were obtained using inlet and outlet piping the same size as the regulator body size.

Table 7. CSB700 Series External Sense Flow Capacities for 20 mbar / 8 in. w.c. Setpoint AC 5 - Industry Performance⁽¹⁾

SETPOINT	SET RANGE	PART NUMBER / COLOR
20 mbar	13 to 24 mbar	ERSA01138A0 / Red
8 in. w.c.	5.2 to 9.6 in. w.c.	

INLET PRESSURE		BODY OUTLET SIZE			
		DN 40 / NPS 1-1/2		DN 50 / NPS 2	
bar	psig	Sm ³ /h	SCFH	Sm ³ /h	SCFH
0.2	2.9	199	7027	163	5756
0.3	4.4	241	8511	200	7063
0.5	7.3	310	10,947	300	10,594
0.8	11.6	394	13,914	379	13,384
1	14.5	439	15,503	434	15,326
1.5	21.8	590	20,835	574	20,270
2	29.0	800	28,251	726	25,638
2.5	36.3	850	30,017	800	28,251
3	43.5	880	31,076	800	28,251
4	58.0	900	31,783	700	24,720
5	72.5	850	30,017	634	22,389
6	87.0	850	30,017	630	22,248
8	116	500	17,657	450	15,891
10	145	450	15,891	405	14,302
12	174				
14	203				
16	232				

Grey areas indicate limited capacities due to boost effects.
1. Industry performances are obtained at single curve at single inlet condition.

Table 8. CSB700 Series External Sense Flow Capacities for 20 mbar / 8 in. w.c. Setpoint AC 10 - Industry Performance⁽¹⁾

SETPOINT	SET RANGE	PART NUMBER / COLOR
20 mbar	13 to 24 mbar	ERSA01138A0 / Red
8 in. w.c.	5.2 to 9.6 in. w.c.	

INLET PRESSURE		BODY OUTLET SIZE			
		DN 40 / NPS 1-1/2		DN 50 / NPS 2	
bar	psig	Sm ³ /h	SCFH	Sm ³ /h	SCFH
0.2	2.9	262	9252	250	8829
0.3	4.4	320	11,300	310	10,947
0.5	7.3	460	16,244	450	15,891
0.8	11.6	601	21,224	580	20,482
1	14.5	680	24,014	628	22,177
1.5	21.8	740	26,132	812	28,675
2	29.0	830	29,311	967	34,149
2.5	36.3	870	30,723	1050	37,080
3	43.5	900	31,783	1150	40,611
4	58.0	937	33,089	1250	44,143
5	72.5	937	33,089	1250	44,143
6	87.0	937	33,089	1200	42,377
8	116	827	29,205	1000	35,314
10	145	800	28,251	900	31,783
12	174				
14	203				
16	232				

Grey areas indicate limited capacities due to boost effects.
1. Industry performances are obtained at single curve at single inlet condition.

Table 9. CSB700 Series External Sense Flow Capacities for 30 mbar / 12 in. w.c. Setpoint AC 5 - Industry Performance⁽¹⁾

SETPOINT	SET RANGE	PART NUMBER / COLOR
30 mbar	22 to 39 mbar	GE30338X012 / Black Stripe
12 in. w.c.	8.8 to 15.7 in. w.c.	

INLET PRESSURE		BODY OUTLET SIZE			
		DN 40 / NPS 1-1/2		DN 50 / NPS 2	
bar	psig	Sm ³ /h	SCFH	Sm ³ /h	SCFH
0.2	2.9	145	5121	166	5862
0.3	4.4	205	7239	211	7451
0.5	7.3	280	9888	297	10,488
0.8	11.6	360	12,713	367	12,960
1	14.5	400	14,126	409	14,443
1.5	21.8	550	19,423	550	19,423
2	29.0	700	24,720	680	24,014
2.5	36.3	850	30,017	860	30,370
3	43.5	1000	35,314	1000	35,314
4	58.0	1100	38,845	1050	37,080
5	72.5	1050	37,080	960	33,901
6	87.0	1000	35,314	900	31,783
8	116	850	30,017	750	26,486
10	145	750	26,486	600	21,188
12	174				
14	203				
16	232				
16	232				

Grey areas indicate limited capacities due to boost effects.
1. Industry performances are obtained at single curve at single inlet condition.

Table 10. CSB700 Series External Sense Flow Capacities for 30 mbar / 12 in. w.c. Setpoint AC 10 - Industry Performance⁽¹⁾

SETPOINT	SET RANGE	PART NUMBER / COLOR
30 mbar	22 to 39 mbar	GE30338X012 / Black Stripe
12 in. w.c.	8.8 to 15.7 in. w.c.	

INLET PRESSURE		BODY OUTLET SIZE			
		DN 40 / NPS 1-1/2		DN 50 / NPS 2	
bar	psig	Sm ³ /h	SCFH	Sm ³ /h	SCFH
0.2	2.9	239	8440	252	8899
0.3	4.4	296	10,453	317	11,195
0.5	7.3	425	15,008	415	14,655
0.8	11.6	540	19,070	557	19,670
1	14.5	600	21,188	640	22,601
1.5	21.8	800	28,251	822	29,028
2	29.0	900	31,783	1004	35,455
2.5	36.3	1000	35,314	1120	39,552
3	43.5	1100	38,845	1200	42,377
4	58.0	1250	44,143	1350	47,674
5	72.5	1350	47,674	1450	51,205
6	87.0	1400	49,440	1500	52,971
8	116	1340	47,321	1451	51,241
10	145	1200	42,377	1300	45,908
12	174				
14	203				
16	232				
16	232				

Grey areas indicate limited capacities due to boost effects.
1. Industry performances are obtained at single curve at single inlet condition.

Table 11. CSB700 Series External Sense Flow Capacities for 40 mbar / 16 in. w.c. Setpoint AC 5 - Industry Performance⁽¹⁾

SETPOINT	SET RANGE	PART NUMBER / COLOR
40 mbar	32 to 50 mbar	GE30339X012 / Purple
16 in. w.c.	12.8 to 20.1 in. w.c.	

INLET PRESSURE		BODY OUTLET SIZE			
		DN 40 / NPS 1-1/2		DN 50 / NPS 2	
bar	psig	Sm ³ /h	SCFH	Sm ³ /h	SCFH
0.2	2.9	152	5368	181	6392
0.3	4.4	217	7663	240	8475
0.5	7.3	259	9146	282	9959
0.8	11.6	398	14,055	366	12,925
1	14.5	437	15,432	438	15,468
1.5	21.8	609	21,506	599	21,153
2	29.0	755	26,662	778	27,474
2.5	36.3	868	30,653	917	32,383
3	43.5	1020	36,020	1050	37,080
4	58.0	1150	40,611	1200	42,377
5	72.5	1260	44,496	1350	47,674
6	87.0	1300	45,908	1400	49,440
8	116	1300	45,908	1400	49,440
10	145	1100	38,845	1200	42,377
12	174				
14	203				
16	232				
16	232				

Grey areas indicate limited capacities due to boost effects.
1. Industry performances are obtained at single curve at single inlet condition.

Table 12. CSB700 Series External Sense Flow Capacities for 40 mbar / 16 in. w.c. Setpoint AC 10 - Industry Performance⁽¹⁾

SETPOINT	SET RANGE	PART NUMBER / COLOR
40 mbar	32 to 50 mbar	GE30339X012 / Purple
16 in. w.c.	12.8 to 20.1 in. w.c.	

INLET PRESSURE		BODY OUTLET SIZE			
		DN 40 / NPS 1-1/2		DN 50 / NPS 2	
bar	psig	Sm ³ /h	SCFH	Sm ³ /h	SCFH
0.2	2.9	245	8652	277	9782
0.3	4.4	300	10,594	336	11,866
0.5	7.3	420	14,832	424	14,973
0.8	11.6	550	19,423	582	20,553
1	14.5	600	21,188	656	23,166
1.5	21.8	783	27,651	844	29,805
2	29.0	966	34,113	1065	37,609
2.5	36.3	1075	37,963	1250	44,143
3	43.5	1150	40,611	1351	47,709
4	58.0	1300	45,908	1480	52,265
5	72.5	1450	51,205	1596	56,361
6	87.0	1500	52,971	1700	60,034
8	116	1600	56,502	1684	59,469
10	145	1400	49,440	1480	52,265
12	174				
14	203				
16	232				
16	232				

Grey areas indicate limited capacities due to boost effects.
1. Industry performances are obtained at single curve at single inlet condition.

CSB700 Series

Table 13. CSB700 Series External Sense Flow Capacities for 50 mbar / 20 in. w.c. Setpoint AC 5 - Industry Performance⁽¹⁾

SETPOINT	SET RANGE	PART NUMBER / COLOR
50 mbar	42 to 70 mbar	GE30340X012 / White Stripe
20 in. w.c.	16.9 to 28.1 in. w.c.	

INLET PRESSURE		BODY OUTLET SIZE			
		DN 40 / NPS 1-1/2		DN 50 / NPS 2	
bar	psig	Sm ³ /h	SCFH	Sm ³ /h	SCFH
0.2	2.9	148	5226	169	5968
0.3	4.4	211	7451	221	7804
0.5	7.3	306	10,806	305	10,771
0.8	11.6	400	14,126	412	14,549
1	14.5	450	15,891	468	16,527
1.5	21.8	620	21,895	607	21,436
2	29.0	732	25,850	754	26,627
2.5	36.3	900	31,783	957	33,795
3	43.5	1050	37,080	1091	38,528
4	58.0	1300	45,908	1382	48,804
5	72.5	1450	51,205	1683	59,433
6	87.0	1500	52,971	1863	65,790
8	116	1450	51,205	2190	77,338
10	145	1300	45,908	2292	80,940
12	174				
14	203				
16	232				
16	232				

Grey areas indicate limited capacities due to boost effects.
1. Industry performances are obtained at single curve at single inlet condition.

Table 14. CSB700 Series External Sense Flow Capacities for 50 mbar / 20 in. w.c. Setpoint AC 10 - Industry Performance⁽¹⁾

SETPOINT	SET RANGE	PART NUMBER / COLOR
50 mbar	42 to 70 mbar	GE30340X012 / White Stripe
20 in. w.c.	16.9 to 28.1 in. w.c.	

INLET PRESSURE		BODY OUTLET SIZE			
		DN 40 / NPS 1-1/2		DN 50 / NPS 2	
bar	psig	Sm ³ /h	SCFH	Sm ³ /h	SCFH
0.2	2.9	227	8016	249	8793
0.3	4.4	313	11,053	318	11,230
0.5	7.3	440	15,538	465	16,421
0.8	11.6	540	19,070	620	21,895
1	14.5	648	22,883	702	24,790
1.5	21.8	835	29,487	878	31,006
2	29.0	1000	35,314	1114	39,340
2.5	36.3	1230	43,436	1250	44,143
3	43.5	1400	49,440	1479	52,229
4	58.0	1550	54,737	1811	63,954
5	72.5	1700	60,034	2023	71,440
6	87.0	1750	61,800	2200	77,691
8	116	1750	61,800	2550	90,051
10	145	1730	61,093	2700	95,348
12	174				
14	203				
16	232				
16	232				

Grey areas indicate limited capacities due to boost effects.
1. Industry performances are obtained at single curve at single inlet condition.

Table 15. CSB700 Series External Sense Flow Capacities for 75 mbar / 30 in. w.c. Setpoint AC 5 - Industry Performance⁽¹⁾

SETPOINT	SET RANGE	PART NUMBER / COLOR
75 mbar	61 to 110 mbar	ERSA03656A0 / Dark Green
30 in. w.c.	0.9 to 1.6 psig	

INLET PRESSURE		BODY OUTLET SIZE			
		DN 40 / NPS 1-1/2		DN 50 / NPS 2	
bar	psig	Sm ³ /h	SCFH	Sm ³ /h	SCFH
0.2	2.9	172	6074	187	6604
0.3	4.4	244	8617	260	9182
0.5	7.3	338	11,936	300	10,594
0.8	11.6	422	14,903	450	15,891
1	14.5	499	17,622	528	18,646
1.5	21.8	635	22,424	701	24,755
2	29.0	770	27,192	839	29,628
2.5	36.3	900	31,783	1022	36,091
3	43.5	1121	39,587	1200	42,377
4	58.0	1577	55,690	1490	52,618
5	72.5	1700	60,034	1800	63,565
6	87.0	1700	60,034	2100	74,159
8	116	1700	60,034	2780	98,173
10	145	1700	60,034	2861	101,033
12	174				
14	203				
16	232				
16	232				

Grey areas indicate limited capacities due to boost effects.
1. Industry performances are obtained at single curve at single inlet condition.

Table 16. CSB700 Series External Sense Flow Capacities for 75 mbar / 30 in. w.c. Setpoint AC 10 - Industry Performance⁽¹⁾

SETPOINT	SET RANGE	PART NUMBER / COLOR
75 mbar	61 to 110 mbar	ERSA03656A0 / Dark Green
30 in. w.c.	0.9 to 1.6 psig	

INLET PRESSURE		BODY OUTLET SIZE			
		DN 40 / NPS 1-1/2		DN 50 / NPS 2	
bar	psig	Sm ³ /h	SCFH	Sm ³ /h	SCFH
0.2	2.9	213	7522	231	8158
0.3	4.4	322	11,371	360	12,713
0.5	7.3	439	15,503	460	16,244
0.8	11.6	570	20,129	665	23,484
1	14.5	650	22,954	753	26,591
1.5	21.8	844	29,805	941	33,230
2	29.0	1000	35,314	1188	41,953
2.5	36.3	1360	48,027	1290	45,555
3	43.5	1420	50,146	1617	57,103
4	58.0	1800	63,565	1950	68,862
5	72.5	2000	70,628	2200	77,691
6	87.0	2100	74,159	2500	88,285
8	116	2300	81,222	3100	109,473
10	145	2300	81,222	3300	116,536
12	174				
14	203				
16	232				
16	232				

Grey areas indicate limited capacities due to boost effects.
1. Industry performances are obtained at single curve at single inlet condition.

Table 17. CSB700 Series External Sense Flow Capacities for 100 mbar / 40 in. w.c. Setpoint AC 5 - Industry Performance⁽¹⁾

SETPOINT	SET RANGE	PART NUMBER / COLOR
100 mbar	61 to 110 mbar	ERSA03656A0 / Dark Green
40 in. w.c.	0.9 to 1.6 psig	

INLET PRESSURE		BODY OUTLET SIZE			
		DN 40 / NPS 1-1/2		DN 50 / NPS 2	
bar	psig	Sm ³ /h	SCFH	Sm ³ /h	SCFH
0.2	2.9	152	5368	150	5297
0.3	4.4	235	8299	250	8829
0.5	7.3	283	9994	340	12,007
0.8	11.6	405	14,302	473	16,704
1	14.5	462	16,315	544	19,211
1.5	21.8	657	23,201	765	27,015
2	29.0	849	29,982	1025	36,197
2.5	36.3	1005	35,491	1232	43,507
3	43.5	1229	43,401	1406	49,651
4	58.0	1529	53,995	1835	64,801
5	72.5	1671	59,010	2152	75,996
6	87.0	1744	61,588	2379	84,012
8	116	2435	85,990	3115	110,003
10	145	2832	100,009	2520	88,991
12	174	3313	116,995	2350	82,988
14	203	4063	14,3481	2124	75,007
16	232	3704	130,803	1756	62,011

1. Industry performances are obtained at single curve at single inlet condition.

Table 18. CSB700 Series External Sense Flow Capacities for 100 mbar / 40 in. w.c. Setpoint AC 10 - Industry Performance⁽¹⁾

SETPOINT	SET RANGE	PART NUMBER / COLOR
100 mbar	61 to 110 mbar	ERSA03656A0 / Dark Green
40 in. w.c.	0.9 to 1.6 psig	

INLET PRESSURE		BODY OUTLET SIZE			
		DN 40 / NPS 1-1/2		DN 50 / NPS 2	
bar	psig	Sm ³ /h	SCFH	Sm ³ /h	SCFH
0.2	2.9	218	7698	230	8122
0.3	4.4	300	10,594	330	11,654
0.5	7.3	401	14,161	501	17,692
0.8	11.6	569	20,094	691	24,402
1	14.5	682	24,084	779	27,510
1.5	21.8	898	31,712	1019	35,985
2	29.0	1121	39,587	1288	45,484
2.5	36.3	1339	47,285	1515	53,501
3	43.5	1467	51,806	1774	62,647
4	58.0	1897	66,991	2138	75,501
5	72.5	2129	75,184	2577	91,004
6	87.0	2294	81,010	2931	103,505
8	116	3072	108,485	3681	129,991
10	145	3469	122,504	4531	160,008
12	174	4021	141,998	5239	185,010
14	203	4324	152,698	6173	217,993
16	232	3860	136,312	6881	242,996

1. Industry performances are obtained at single curve at single inlet condition.

Table 19. CSB700 Series External Sense Flow Capacities for 150 mbar / 60 in. w.c. Setpoint AC 5 - Industry Performance⁽¹⁾

SETPOINT	SET RANGE	PART NUMBER / COLOR
150 mbar	105 to 220 mbar	ERSA03657A0 / Blue
60 in. w.c.	1.5 to 3.2 psig	

INLET PRESSURE		BODY OUTLET SIZE			
		DN 40 / NPS 1-1/2		DN 50 / NPS 2	
bar	psig	Sm ³ /h	SCFH	Sm ³ /h	SCFH
0.2	2.9	108	3814	110	3885
0.3	4.4	185	6533	200	7063
0.5	7.3	266	9394	280	9888
0.8	11.6	368	12,996	399	14,090
1	14.5	430	15,185	456	16,103
1.5	21.8	580	20,482	651	22,989
2	29.0	736	25,991	855	30,193
2.5	36.3	878	31,006	1076	37,998
3	43.5	991	34,996	1232	43,507
4	58.0	1359	47,992	1702	60,104
5	72.5	1628	57,491	2067	72,994
6	87.0	1713	60,493	2379	84,012
8	116	2344	82,776	3087	109,014
10	145	2967	104,777	3596	126,989
12	174	3455	122,010	4417	155,982
14	203	3681	129,991	5154	182,008
16	232	3540	125,012	5805	204,998

1. Industry performances are obtained at single curve at single inlet condition.

Table 20. CSB700 Series External Sense Flow Capacities for 150 mbar / 60 in. w.c. Setpoint AC 10 - Industry Performance⁽¹⁾

SETPOINT	SET RANGE	PART NUMBER / COLOR
150 mbar	105 to 220 mbar	ERSA03657A0 / Blue
60 in. w.c.	1.5 to 3.2 psig	

INLET PRESSURE		BODY OUTLET SIZE			
		DN 40 / NPS 1-1/2		DN 50 / NPS 2	
bar	psig	Sm ³ /h	SCFH	Sm ³ /h	SCFH
0.2	2.9	180	6357	190	6710
0.3	4.4	280	9888	280	9888
0.5	7.3	404	14,267	445	15,715
0.8	11.6	552	19,493	643	22,707
1	14.5	646	22,813	745	26,309
1.5	21.8	852	30,088	997	35,208
2	29.0	1048	37,009	1223	43,189
2.5	36.3	1274	44,990	1388	49,016
3	43.5	1455	51,382	1699	59,998
4	58.0	1702	60,104	2110	74,513
5	72.5	2010	70,981	2512	88,709
6	87.0	2152	75,996	2888	101,987
8	116	3058	107,990	3681	129,991
10	145	3688	130,238	4559	160,997
12	174	4545	160,502	5256	185,610
14	203	4460	157,500	6088	214,992
16	232	4304	151,991	7000	247,198

1. Industry performances are obtained at single curve at single inlet condition.

CSB700 Series

Table 21. CSB700 Series External Sense Flow Capacities for 300 mbar / 4.35 psig Setpoint AC 5 - Industry Performance⁽¹⁾

SETPOINT	SET RANGE	PART NUMBER / COLOR
300 mbar	210 to 380 mbar	GG06247X012 / Black
4.35 psig	3.1 to 5.5 psig	

INLET PRESSURE		BODY OUTLET SIZE			
		DN 40 / NPS 1-1/2		DN 50 / NPS 2	
bar	psig	Sm ³ /h	SCFH	Sm ³ /h	SCFH
0.5	7.3	216	7628	250	8829
0.8	11.6	354	12,501	400	14,126
1	14.5	408	14,408	510	18,010
1.5	21.8	580	20,482	694	24,508
2	29.0	736	25,991	878	31,006
2.5	36.3	892	31,500	1090	38,492
3	43.5	1076	37,998	1288	45,484
4	58.0	1331	47,003	1713	60,493
5	72.5	1713	60,493	2050	72,394
6	87.0	1775	62,682	2300	81,222
8	116	2237	78,997	3100	109,473
10	145	2832	100,009	3900	137,725
12	174	3256	114,982	4400	155,382
14	203	3933	138,890	5110	180,455
16	232	4531	160,008	5900	208,353

1. Industry performances are obtained at single curve at single inlet condition.

Table 22. CSB700 Series External Sense Flow Capacities for 300 mbar / 4.35 psig Setpoint AC 10 - Industry Performance⁽¹⁾

SETPOINT	SET RANGE	PART NUMBER / COLOR
300 mbar	210 to 380 mbar	GG06247X012 / Black
4.35 psig	3.1 to 5.5 psig	

INLET PRESSURE		BODY OUTLET SIZE			
		DN 40 / NPS 1-1/2		DN 50 / NPS 2	
bar	psig	Sm ³ /h	SCFH	Sm ³ /h	SCFH
0.5	7.3	340	12,007	400	14,126
0.8	11.6	507	17,904	630	22,248
1	14.5	623	22,001	765	27,015
1.5	21.8	866	30,582	1000	35,314
2	29.0	1079	38,104	1250	44,143
2.5	36.3	1288	45,484	1500	52,971
3	43.5	1461	51,594	1700	60,034
4	58.0	1911	67,485	2110	74,513
5	72.5	2223	78,503	2610	92,170
6	87.0	2435	85,990	2900	102,411
8	116	3370	119,008	3800	134,193
10	145	3851	135,994	4800	169,507
12	174	4587	161,985	5500	194,227
14	203	5394	190,484	6257	220,960
16	232	6145	217,005	7000	247,198

1. Industry performances are obtained at single curve at single inlet condition.

Table 23. CSB700 Series External Sense Flow Capacities for 500 mbar / 7.25 psig Setpoint AC 5 - Industry Performance⁽¹⁾

SETPOINT	SET RANGE	PART NUMBER / COLOR
500 mbar	320 to 570 mbar	ERSA01582A0 / Red with White Stripe
7.25 psig	4.6 to 8.3 psig	

INLET PRESSURE		BODY OUTLET SIZE			
		DN 40 / NPS 1-1/2		DN 50 / NPS 2	
bar	psig	Sm ³ /h	SCFH	Sm ³ /h	SCFH
0.8	11.6	278	9817	297	10,488
1	14.5	348	12,289	374	13,207
1.5	21.8	518	18,293	552	19,493
2	29.0	668	23,590	711	25,108
2.5	36.3	813	28,710	849	29,982
3	43.5	943	33,301	1005	35,491
4	58.0	1260	44,496	1359	47,992
5	72.5	1501	53,006	1699	59,998
6	87.0	1784	63,000	1954	69,004
8	116	2336	82,494	2605	91,993
10	145	2832	100,009	3290	116,183
12	174	3398	119,997	4021	141,998
14	203	3879	136,983	4638	163,786
16	232	4531	160,008	4559	160,997

1. Industry performances are obtained at single curve at single inlet condition.

Table 24. CSB700 Series External Sense Flow Capacities for 500 mbar / 7.25 psig Setpoint AC 10 - Industry Performance⁽¹⁾

SETPOINT	SET RANGE	PART NUMBER / COLOR
500 mbar	320 to 570 mbar	ERSA01582A0 / Red with White Stripe
7.25 psig	4.6 to 8.3 psig	

INLET PRESSURE		BODY OUTLET SIZE			
		DN 40 / NPS 1-1/2		DN 50 / NPS 2	
bar	psig	Sm ³ /h	SCFH	Sm ³ /h	SCFH
0.8	11.6	456	16,103	501	17,692
1	14.5	572	20,200	623	22,001
1.5	21.8	818	28,887	892	31,500
2	29.0	1048	37,009	1133	40,011
2.5	36.3	1263	44,602	1356	47,886
3	43.5	1444	50,993	1500	52,971
4	58.0	1826	64,483	2042	72,111
5	72.5	2166	76,490	2435	85,990
6	87.0	2548	89,980	2860	100,998
8	116	3305	116,713	3653	129,002
10	145	3998	141,185	4559	160,997
12	174	4695	165,799	5394	190,484
14	203	5394	190,484	6244	220,501
16	232	6088	214,992	7100	250,729

1. Industry performances are obtained at single curve at single inlet condition.

Table 25. CSB700 Series External Sense Flow Capacities for 750 mbar / 10.9 psig Setpoint AC 5 - Industry Performance⁽¹⁾

SETPOINT	SET RANGE	PART NUMBER / COLOR
750 mbar	510 to 780 mbar	ERSA05055A0 / Blue with White Stripe
10.9 psig	7.4 to 11.3 psig	

INLET PRESSURE		BODY OUTLET SIZE			
		DN 40 / NPS 1-1/2		DN 50 / NPS 2	
bar	psig	Sm ³ /h	SCFH	Sm ³ /h	SCFH
0.8	11.6	253	8934	129	4556
1	14.5	380	13,419	300	10,594
1.5	21.8	510	18,010	460	16,244
2	29.0	772	27,262	708	25,002
2.5	36.3	906	31,994	765	27,015
3	43.5	1076	37,998	963	34,007
4	58.0	1487	52,512	1472	51,982
5	72.5	1926	68,015	1841	65,013
6	87.0	2209	78,009	2223	78,503
8	116	2866	101,210	2662	94,006
10	145	3540	125,012	3384	119,503
12	174	4163	147,012	3780	133,487
14	203	4616	163,009	3780	133,487
16	232	5097	179,995	3780	133,487

1. Industry performances are obtained at single curve at single inlet condition.

Table 26. CSB700 Series External Sense Flow Capacities for 750 mbar / 10.9 psig Setpoint AC 10 - Industry Performance⁽¹⁾

SETPOINT	SET RANGE	PART NUMBER / COLOR
750 mbar	510 to 780 mbar	ERSA05055A0 / Blue with White Stripe
10.9 psig	7.4 to 11.3 psig	

INLET PRESSURE		BODY OUTLET SIZE			
		DN 40 / NPS 1-1/2		DN 50 / NPS 2	
bar	psig	Sm ³ /h	SCFH	Sm ³ /h	SCFH
0.8	11.6	340	12,007	399	14,090
1	14.5	545	19,246	552	19,493
1.5	21.8	872	30,794	915	32,312
2	29.0	1119	39,516	1211	42,765
2.5	36.3	1379	48,698	1485	52,441
3	43.5	1600	56,502	1699	59,998
4	58.0	2053	72,500	2166	76,490
5	72.5	2435	85,990	2591	91,499
6	87.0	2809	99,197	3019	106,613
8	116	3596	126,989	3724	131,509
10	145	4361	154,004	4587	161,985
12	174	5168	182,503	5408	190,978
14	203	5748	202,985	6200	218,947
16	232	6329	223,502	7000	247,198

1. Industry performances are obtained at single curve at single inlet condition.

Table 27. CSB700 Series External Sense Flow Capacities for 1 bar / 14.5 psig Setpoint AC 5 - Industry Performance⁽¹⁾

SETPOINT	SET RANGE	PART NUMBER / COLOR
1 bar	0.7 to 1.19 bar	GE30345X012 / Purple Stripe
14.5 psig	10.2 to 17.3 psig	

INLET PRESSURE		BODY OUTLET SIZE			
		DN 40 / NPS 1-1/2		DN 50 / NPS 2	
bar	psig	Sm ³ /h	SCFH	Sm ³ /h	SCFH
1.5	21.8	578	20,411	650	22,954
2	29.0	849	29,982	934	32,983
2.5	36.3	1062	37,503	1130	39,905
3	43.5	1303	46,014	1400	49,440
4	58.0	1722	60,811	1800	63,565
5	72.5	2107	74,407	2250	79,457
6	87.0	2435	85,990	2700	95,348
8	116	3242	114,488	3350	118,302
10	145	3851	135,994	4000	141,256
12	174	4616	163,009	4500	158,913
14	203	5154	182,008	5100	180,101
16	232	5578	196,981	5830	205,881

1. Industry performances are obtained at single curve at single inlet condition.

Table 28. CSB700 Series External Sense Flow Capacities for 1 bar / 14.5 psig Setpoint AC 10 - Industry Performance⁽¹⁾

SETPOINT	SET RANGE	PART NUMBER / COLOR
1 bar	0.7 to 1.19 bar	GE30345X012 / Purple Stripe
14.5 psig	10.2 to 17.3 psig	

INLET PRESSURE		BODY OUTLET SIZE			
		DN 40 / NPS 1-1/2		DN 50 / NPS 2	
bar	psig	Sm ³ /h	SCFH	Sm ³ /h	SCFH
1.5	21.8	789	27,863	835	29,487
2	29.0	1090	38,492	1161	41,000
2.5	36.3	1373	48,486	1400	49,440
3	43.5	1611	56,891	1700	60,034
4	58.0	2073	73,206	2200	77,691
5	72.5	2512	88,709	2650	93,582
6	87.0	2801	98,915	3100	109,473
8	116	3625	128,013	3850	135,959
10	145	4417	155,982	4900	173,039
12	174	5295	186,988	5600	197,758
14	203	5828	205,810	6800	240,135
16	232	6484	228,976	7200	254,261

1. Industry performances are obtained at single curve at single inlet condition.

CSB700 Series

Table 29. CSB700 Series External Sense Flow Capacities for 1.5 bar / 21.8 psig Setpoint AC 5 - Industry Performance⁽¹⁾

SETPOINT	SET RANGE	PART NUMBER / COLOR
1.5 bar	1.05 to 2.7 bar	GE30346X012 / Brown
21.8 psig	15.2 to 39.2 psig	

INLET PRESSURE		BODY OUTLET SIZE			
		DN 40 / NPS 1-1/2		DN 50 / NPS 2	
bar	psig	Sm ³ /h	SCFH	Sm ³ /h	SCFH
2	29.0	629	22,213	650	22,954
2.5	36.3	883	31,182	905	31,959
3	43.5	1099	38,810	1161	41,000
4	58.0	1487	52,512	1586	56,008
5	72.5	1897	66,991	1991	70,310
6	87.0	2279	80,481	2421	85,495
8	116	3030	107,001	3150	111,239
10	145	3766	132,993	3900	137,725
12	174	4347	153,510	4750	167,742
14	203	5040	177,983	5239	185,010
16	232	5539	195,604	6030	212,943

1. Industry performances are obtained at single curve at single inlet condition.

Table 30. CSB700 Series External Sense Flow Capacities for 1.5 bar / 21.8 psig Setpoint AC 10 - Industry Performance⁽¹⁾

SETPOINT	SET RANGE	PART NUMBER / COLOR
1.5 bar	1.05 to 2.7 bar	GE30346X012 / Brown
21.8 psig	15.2 to 39.2 psig	

INLET PRESSURE		BODY OUTLET SIZE			
		DN 40 / NPS 1-1/2		DN 50 / NPS 2	
bar	psig	Sm ³ /h	SCFH	Sm ³ /h	SCFH
2	29.0	937	33,089	1034	36,515
2.5	36.3	1269	44,813	1334	47,109
3	43.5	1523	53,783	1640	57,915
4	58.0	1991	70,310	2158	76,208
5	72.5	2458	86,802	2600	91,816
6	87.0	2815	99,409	3080	108,767
8	116	3639	128,508	4020	141,962
10	145	4502	158,984	4885	172,509
12	174	5352	189,001	5770	203,762
14	203	6060	214,003	6650	234,838
16	232	6836	241,407	7150	252,495

1. Industry performances are obtained at single curve at single inlet condition.

Table 31. CSB700 Series External Sense Flow Capacities for 2 bar / 29 psig Setpoint AC 5 - Industry Performance⁽¹⁾

SETPOINT	SET RANGE	PART NUMBER / COLOR
2 bar	1.05 to 2.7 bar	GE30346X012 / Brown
29 psig	15.2 to 39.2 psig	

INLET PRESSURE		BODY OUTLET SIZE			
		DN 40 / NPS 1-1/2		DN 50 / NPS 2	
bar	psig	Sm ³ /h	SCFH	Sm ³ /h	SCFH
2.5	36.3	787	27,792	900	31,783
3	43.5	1104	38,987	1218	43,012
4	58.0	1600	56,502	1671	59,010
5	72.5	2005	70,805	2129	75,184
6	87.0	2464	87,014	2577	91,004
8	116	3364	118,796	3483	122,999
10	145	4095	144,611	4361	154,004
12	174	4701	166,011	5154	182,008
14	203	5408	190,978	5918	208,988
16	232	5975	211,001	6739	237,981

1. Industry performances are obtained at single curve at single inlet condition.

Table 32. CSB700 Series External Sense Flow Capacities for 2 bar / 29 psig Setpoint AC 10 - Industry Performance⁽¹⁾

SETPOINT	SET RANGE	PART NUMBER / COLOR
2 bar	1.05 to 2.7 bar	GE30346X012 / Brown
29 psig	15.2 to 39.2 psig	

INLET PRESSURE		BODY OUTLET SIZE			
		DN 40 / NPS 1-1/2		DN 50 / NPS 2	
bar	psig	Sm ³ /h	SCFH	Sm ³ /h	SCFH
2.5	36.3	1076	37,998	1130	39,905
3	43.5	1390	49,086	1485	52,441
4	58.0	1948	68,792	2101	74,195
5	72.5	2347	82,882	2582	91,181
6	87.0	2832	100,009	3087	109,014
8	116	3670	129,602	4049	142,986
10	145	4545	160,502	5012	176,994
12	174	5417	191,296	5904	208,494
14	203	6196	218,806	6810	240,488
16	232	6810	240,488	7566	267,186

1. Industry performances are obtained at single curve at single inlet condition.

Table 33. CSB700 Series External Sense Flow Capacities for 3 bar / 43.5 psig Setpoint AC 5 - Industry Performance⁽¹⁾

SETPOINT	SET RANGE	PART NUMBER / COLOR
3 bar	2.3 to 3.25 bar	ERSA01125A0 / Grey with Red Stripe
43.5 psig	33.4 to 47.1 psig	

INLET PRESSURE		BODY OUTLET SIZE			
		DN 40 / NPS 1-1/2		DN 50 / NPS 2	
bar	psig	Sm ³ /h	SCFH	Sm ³ /h	SCFH
4	58.0	1215	42,907	1373	48,486
5	72.5	1727	60,987	1880	66,390
6	87.0	2124	75,007	2294	81,010
8	116	2996	105,801	3132	110,603
10	145	3879	136,983	4078	144,010
12	174	4672	164,987	4955	174,981
14	203	5324	188,012	5734	202,490
16	232	6060	214,003	6513	230,000

1. Industry performances are obtained at single curve at single inlet condition.

Table 34. CSB700 Series External Sense Flow Capacities for 3 bar / 43.5 psig Setpoint AC 10 - Industry Performance⁽¹⁾

SETPOINT	SET RANGE	PART NUMBER / COLOR
3 bar	2.3 to 3.25 bar	ERSA01125A0 / Grey with Red Stripe
43.5 psig	33.4 to 47.1 psig	

INLET PRESSURE		BODY OUTLET SIZE			
		DN 40 / NPS 1-1/2		DN 50 / NPS 2	
bar	psig	Sm ³ /h	SCFH	Sm ³ /h	SCFH
4	58.0	1716	60,599	1821	64,307
5	72.5	2251	79,492	2421	85,495
6	87.0	2667	94,182	2888	101,987
8	116	3653	129,002	3936	138,996
10	145	4539	160,290	4842	170,990
12	174	5442	192,179	5663	199,983
14	203	6286	221,984	6669	235,509
16	232	7136	252,001	7550	266,621

1. Industry performances are obtained at single curve at single inlet condition.

Table 35. CSB700 Series External Sense Flow Capacities for 4 bar / 58 psig Setpoint AC 5 - Industry Performance⁽¹⁾

SETPOINT	SET RANGE	PART NUMBER / COLOR
4 bar	3.1 to 4 bar	ERSA01126A0 / Grey with Orange Stripe
58 psig	45 to 58 psig	

INLET PRESSURE		BODY OUTLET SIZE			
		DN 40 / NPS 1-1/2		DN 50 / NPS 2	
bar	psig	Sm ³ /h	SCFH	Sm ³ /h	SCFH
5	72.5	1314	46,403	1472	51,982
6	87.0	1841	65,013	1982	69,992
8	116	2775	97,996	2832	100,009
10	145	3658	129,179	3625	128,013
12	174	4361	154,004	4474	157,995
14	203	5125	180,984	5324	188,012
16	232	5833	205,987	6088	214,992

1. Industry performances are obtained at single curve at single inlet condition.

Table 36. CSB700 Series External Sense Flow Capacities for 4 bar / 58 psig Setpoint AC 10 - Industry Performance⁽¹⁾

SETPOINT	SET RANGE	PART NUMBER / COLOR
4.0 bar	3.1 to 4 bar	ERSA01126A0 / Grey with Orange Stripe
58 psig	45 to 58 psig	

INLET PRESSURE		BODY OUTLET SIZE			
		DN 40 / NPS 1-1/2		DN 50 / NPS 2	
bar	psig	Sm ³ /h	SCFH	Sm ³ /h	SCFH
5	72.5	1883	66,496	2074	73,241
6	87.0	2500	88,285	2502	88,356
8	116	3534	124,800	3637	128,437
10	145	4485	158,383	4695	165,799
12	174	5408	190,978	5692	201,007
14	203	6272	221,489	6654	234,979
16	232	7037	248,505	7391	261,006

1. Industry performances are obtained at single curve at single inlet condition.

CSB700 Series

EN334 Utility Performance Data

Table 37. CSB700 Series External (Pressure Registration) - Flow Capacities for DN 50 / NPS 2 Body, AC 5 Accuracy - Utility Performance⁽¹⁾

CAPACITIES IN Sm ³ h OF 0.6 SPECIFIC GRAVITY NATURAL GAS																								
Inlet Pressure Group		Inlet		Outlet Pressure, bar / psig																				
bar	psig	bar	psig	0.02 / 0.29	0.03 / 0.44	0.04 / 0.58	0.05 / 0.73	0.075 / 1.1	0.1 / 1.5	0.15 / 2.2	0.3 / 4.4	0.5 / 7.3	0.75 / 10.9	1 / 14.5	1.15 / 21.8	2 / 29.0	3 / 43.5	4 / 58.0						
0.2 to 0.3	2.9 to 4.4	0.2	2.9	163	166	181	169	187	150	110														
		0.3	4.4	200	211	240	221	260	250	200														
0.5 to 3	7.3 to 43.5	0.5	7.3	281	281	277	305	265	340	280	250													
		0.8	11.6	360	362	357	405	360	473	399	400										297	129		
		1	14.5	360	409	438	463	415	544	456	510										374	300		
		1.5	21.8	574	500	563	607	701	765	651	694										552	460	650	
		2	29.0	726	680	725	754	839	1025	855	878										711	708	934	650
		2.5	36.3	636	680	888	937	1022	1232	1076	1090										849	765	1130	905
		3	43.5	554	800	941	1060	1200	1406	1232	1288	1005	963	1400	1161	1218								
4 to 6	58.0 to 87.0	4	58.0	612	1050	1027	1370	1426	1835	1702	1713	1359	1472	1800	1586	1671			1373					
		5	72.5	634	800	1160	1683	1800	2152	2067	2050	1699	1841	2250	1991	2129			1880	1472				
		6	87.0	630	620	1076	1524	2100	2379	2379	2300	1954	2223	2700	2421	2577			2294	1982				
8 to 16	116 to 232	8	116	450	620	1113	2141	2779	3115	3087	3100	2605	2662	3350	3150	3483			3132	2832				
		10	145	405	420	650	2292	2861	2520	3596	3900	3290	3384	4000	3900	4361			4078	3625				
		12	174							2350	4417	4400	4021	3780	4500	4750	5154	4955	4474					
		14	203							2124	5154	5110	4638	3780	5100	5239	5918	5734	5324					
		16	232							1756	5805	5900	4559	3780	5830	6030	6739	6513	6088					

- Grey areas indicate limited capacities due to boost effects.
 1. Utility performances are obtained by determination of the accuracy class related to a specified inlet pressure range and set range (per EN334 Rev November 2014).

Table 38. CSB700 Series External (Pressure Registration) - Flow Capacities for DN 50 / NPS 2 Body, AC 10 Accuracy - Utility Performance⁽¹⁾

CAPACITIES IN Sm ³ h OF 0.6 SPECIFIC GRAVITY NATURAL GAS																								
Inlet Pressure Group		Inlet		Outlet Pressure, bar / psig																				
bar	psig	bar	psig	0.02 / 0.29	0.03 / 0.44	0.04 / 0.58	0.05 / 0.73	0.075 / 1.1	0.1 / 1.5	0.15 / 2.2	0.3 / 4.4	0.5 / 7.3	0.75 / 10.9	1 / 14.5	1.15 / 21.8	2 / 29.0	3 / 43.5	4 / 58.0						
0.2 to 0.3	2.9 to 4.4	0.2	2.9	250	252	277	249	231	230	190														
		0.3	4.4	310	317	336	318	360	330	280														
0.5 to 3	7.3 to 43.5	0.5	7.3	426	408	423	463	429	501	445	400													
		0.8	11.6	564	546	581	612	626	691	643	630										501	399		
		1	14.5	614	630	649	699	732	779	745	765										623	552		
		1.5	21.8	812	806	838	875	941	1019	997	1000										892	915	835	
		2	29.0	967	987	1050	1111	1188	1288	1223	1250										1133	1211	1161	1034
		2.5	36.3	1000	1120	1240	1241	1290	1515	1388	1500										1356	1485	1400	1334
		3	43.5	985	1092	1351	1479	1617	1774	1699	1700	1416	1699	1700	1640	1485								
4 to 6	58.0 to 87.0	4	58.0	1013	1255	1174	1564	1950	2138	2110	2110	2042	2166	2200	2158	2101			1821					
		5	72.5	1104	1255	1596	1949	2200	2577	2512	2610	2435	2591	2650	2600	2582			2421	2074				
		6	87.0	1052	1255	1602	2125	2200	2931	2888	2900	2860	3019	3100	3080	3087			2888	2502				
8 to 16	116 to 232	8	116	1000	1451	1684	2190	2780	3681	3681	3600	3653	3724	3850	4020	4049			3936	3637				
		10	145	704	1200	1282	2292	2861	4531	4559	4800	4559	4587	4900	4885	5012			4842	4695				
		12	174							5239	5256	5500	5394	5408	5600	5770	5904	5663	5692					
		14	203							6173	6088	6257	6244	6200	6800	6650	6810	6669	6654					
		16	232							6881	7000	7000	7000	7000	7200	7150	7566	7550	7391					

- Grey areas indicate limited capacities due to boost effects.
 1. Utility performances are obtained by determination of the accuracy class related to a specified inlet pressure range and set range (per EN334 Rev November 2014).

Table 39. CSB700 Series External (Pressure Registration) - Flow Capacities for DN 40 / NPS 1-1/2 Body, AC 5 Accuracy - Utility Performance⁽¹⁾

CAPACITIES IN Sm ³ h OF 0.6 SPECIFIC GRAVITY NATURAL GAS																								
Inlet Pressure Group		Inlet		Outlet Pressure, bar / psig																				
bar	psig	bar	psig	0.02 / 0.29	0.03 / 0.44	0.04 / 0.58	0.05 / 0.73	0.075 / 1.1	0.1 / 1.5	0.15 / 2.2	0.3 / 4.4	0.5 / 7.3	0.75 / 10.9	1 / 14.5	1.15 / 21.8	2 / 29.0	3 / 43.5	4 / 58.0						
0.2 to 0.3	2.9 to 4.4	0.2	2.9	187	145	150	147	172	152	104														
		0.3	4.4	240	205	215	209	244	235	185														
0.5 to 3	7.3 to 43.5	0.5	7.3	310	259	259	302	296	283	266	216													
		0.8	11.6	394	340	386	400	356	405	368	354									278	253			
		1	14.5	430	353	426	450	435	462	430	408									348	380			
		1.5	21.8	548	496	592	615	635	657	580	580									518	510	578		
		2	29.0	769	643	728	730	770	849	736	736									668	772	849	629	
		2.5	36.3	800	794	868	900	900	1005	878	892									813	906	1062	883	787
		3	43.5	800	946	1020	900	1121	1229	991	1076									943	1076	1303	1099	1104
4 to 6	58.0 to 87.0	4	58.0	850	1000	1085	1220	1550	1529	1359	1331	1260	1487	1722	1487	1600	1215							
		5	72.5	574	1000	1085	1250	1650	1671	1628	1713	1501	1926	2107	1897	2005	1727			1314				
		6	87.0	497	1000	1085	1250	1700	1744	1713	1775	1784	2209	2435	2279	2464	2124			1841				
8 to 16	116 to 232	8	116	471	470	1082	1250	1700	2435	2344	2237	2336	2866	3242	3030	3364	2996	2775						
		10	145	450	461	1100	1250	1700	2832	2967	2832	2832	3540	3851	3766	4095	3879	3658						
		12	174							3313	3455	3256	3398	4163	4616	4347	4701	4672			4361			
		14	203							4063	3681	3393	3879	4616	5154	5040	5408	5324			5125			
		16	232							3704	3540	4531	4531	5097	5578	5539	5975	6060			5833			

- Grey areas indicate limited capacities due to boost effects.
 1. Utility performances are obtained by determination of the accuracy class related to a specified inlet pressure range and set range (per EN334 Rev November 2014).

CSB700 Series

Table 40. CSB700 Series External (Pressure Registration) - Flow Capacities for DN 40 / NPS 1-1/2 Body, AC 10 Accuracy - Utility Performance⁽¹⁾

CAPACITIES IN Sm ³ h OF 0.6 SPECIFIC GRAVITY NATURAL GAS																			
Inlet Pressure Group		Inlet		Outlet Pressure, bar / psig															
bar	psig	bar	psig	0.02 / 0.29	0.03 / 0.44	0.04 / 0.58	0.05 / 0.73	0.075 / 1.1	0.1 / 1.5	0.15 / 2.2	0.3 / 4.4	0.5 / 7.3	0.75 / 10.9	1 / 14.5	1.15 / 21.8	2 / 29.0	3 / 43.5	4 / 58.0	
0.2 to 0.3	2.9 to 4.4	0.2	2.9	248	227	245	220	213	218	180									
		0.3	4.4	309	291	218	312	322	300	280									
0.5 to 3	7.3 to 43.5	0.5	7.3	460	425	420	440	439	401	404	340								
		0.8	11.6	537	500	540	540	570	569	552	507	456	340						
		1	14.5	615	568	600	648	650	682	646	623	572	545						
		1.5	21.8	740	726	780	835	844	898	852	866	818	872	789					
		2	29.0	830	898	948	1000	1000	1121	1048	1079	1048	1119	1090	937				
		2.5	36.3	840	1000	1075	1230	1360	1339	1274	1288	1263	1379	1373	1269	1076			
		3	43.5	900	1000	1075	1320	1400	1467	1455	1461	1444	1600	1611	1523	1390			
4 to 6	58.0 to 87.0	4	58.0	937	1200	1100	1550	1580	1897	1702	1911	1826	2053	2073	1991	1948	1716		
		5	72.5	937	1300	1118	1700	1700	2129	2010	2223	2166	2435	2512	2458	2347	2251	1883	
		6	87.0	937	1300	1290	1750	1880	2294	2152	2435	2548	2809	2801	2815	2832	2667	2500	
8 to 16	116 to 232	8	116	760	960	1230	1750	1880	3072	3058	3370	3305	3596	3625	3639	3670	3653	3534	
		10	145	674	850	1032	1730	1880	3469	3688	3851	3998	4361	4417	4502	4545	4539	4485	
		12	174							4021	4545	4587	4695	5168	5295	5352	5417	5442	5408
		14	203							4324	4460	5394	5394	5748	5828	6060	6196	6286	6272
		16	232							3860	4304	6145	6088	6329	6484	6836	6810	7136	7037

- Grey areas indicate limited capacities due to boost effects.
 1. Utility performances are obtained by determination of the accuracy class related to a specified inlet pressure range and set range (per EN334 Rev November 2014).

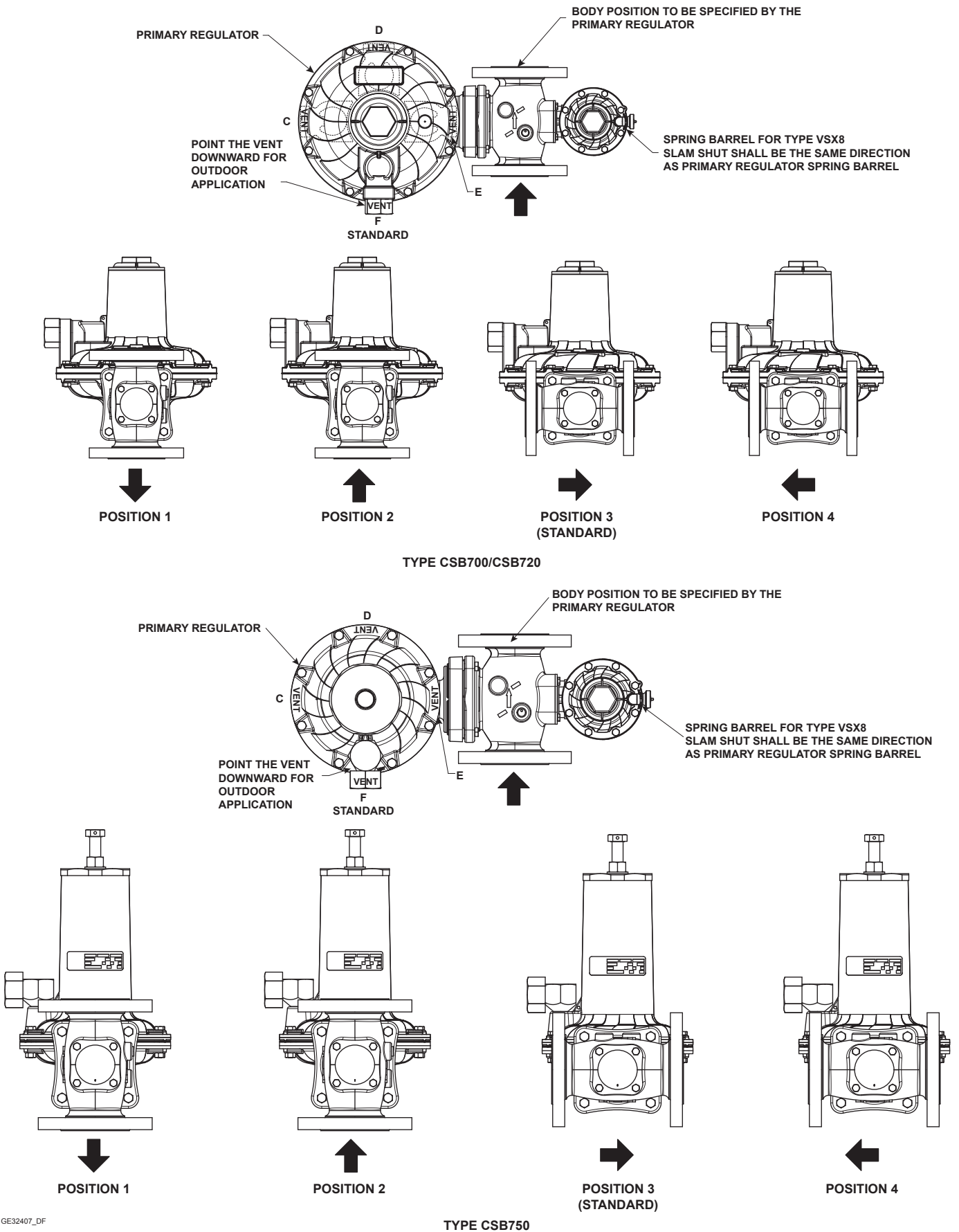

GE32407_DF

Figure 5. CSB700 Series Vent and Body Positions

CSB700 Series

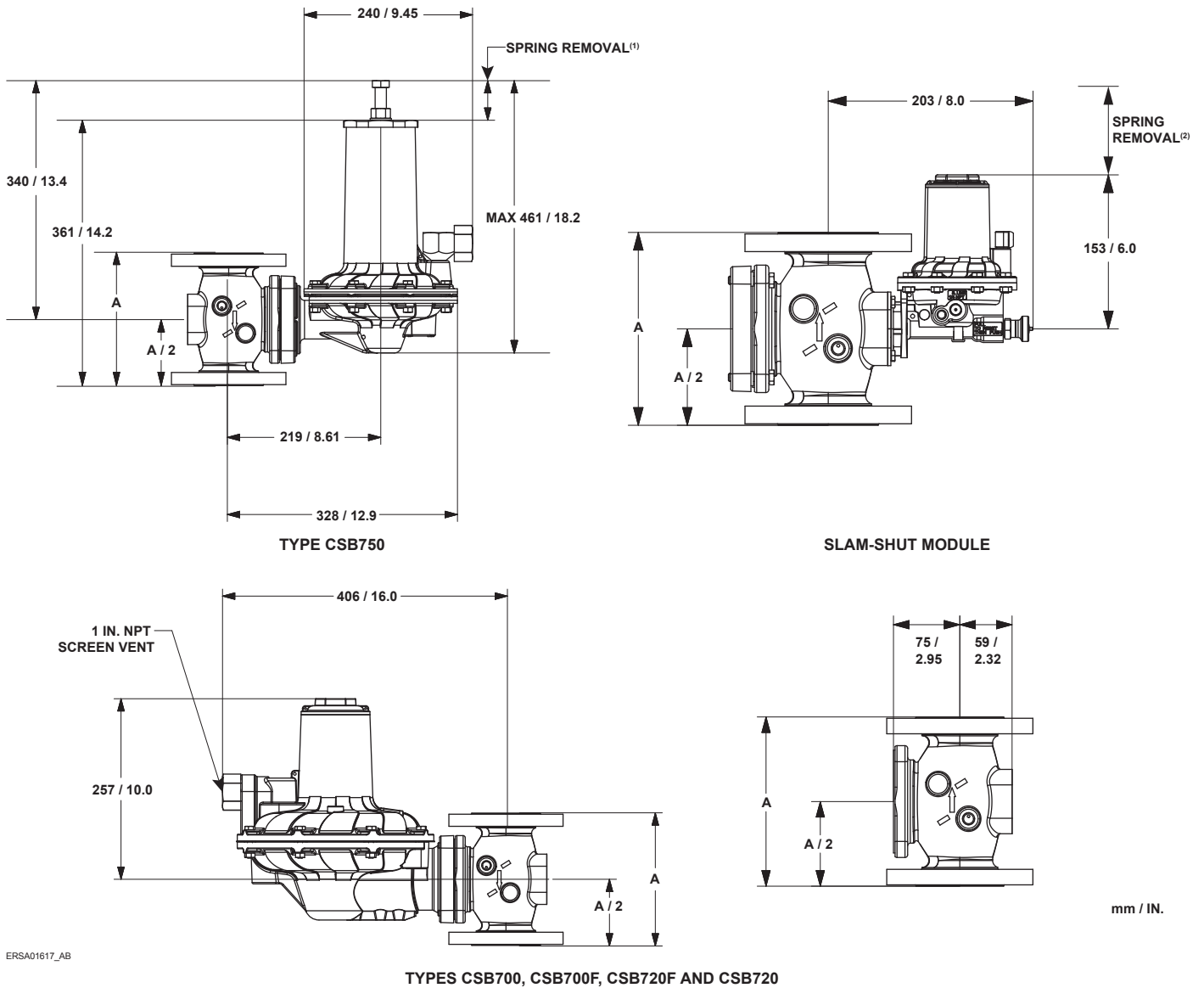

ERSA01617_AB

TYPES CSB700, CSB700F, CSB720F AND CSB720

1. Maximum spring removal clearance for the primary regulator is 158 mm / 6.2 in.
2. Maximum spring removal clearance for the slam shut is 80 mm / 3.1 in.

Figure 6. CSB700 Series Dimensions

Table 41. CSB700 Series Dimensions

BODY SIZE		BODY END CONNECTION STYLE	FACE-TO-FACE DIAMETER (A)	
DN	NPS		mm	In.
40	1-1/2	NPT or Rp	155	6.10
50	2	NPT or Rp	155	6.10
50	2	CL125 FF or CL150 FF	191	7.52
			254	10.0
			267	10.5
		CL150 RF	254	10.0
		PN 10/16	191	7.52
40	1-1/2	PN 16 Slip-on	200	7.87
			254	10.0
			222	8.74

Ordering Information

When ordering, complete the ordering guide on this page. Refer to the Specifications section on page 2. Review the description to the right of each

specification and the information in each referenced table or figure. Specify your choice whenever a selection is offered.

Ordering Guide

Type (See Table 1 for Construction details)
(Select One)

Stand-Alone Regulator

- CSB700EN CSB720FEN
- CSB700ET CSB720EN
- CSB700FEN CSB720ET
- CSB700FET CSB750EN

With Type VSX8 Slam-Shut Module

- CSB704EN CSB724FEN
- CSB704ET CSB724EN
- CSB704FEN CSB724ET
- CSB704FET CSB754EN

Body Size and End Connection Style (Select One)

Ductile Iron

- 1-1/2 NPT
- 2 NPT***
- Rp 1-1/2***
- Rp 2***
- NPS 2 / DN 50, CL125 FF***
- NPS 2 / DN 50, CL150 FF***
- NPS 2 / DN 50, PN 10/16***
- NPS 1-1/2 / DN 40, PN 16 slip-on flanged body

WCC Steel

- 1-1/2 NPT***
- 2 NPT***
- Rp 1-1/2***
- Rp 2***
- NPS 2 / DN 50, CL150 RF
- NPS 2 / DN 50, PN 10/16

Outlet Pressure Range (Select One)

Type CSB700/CSB704

- 9 to 14 mbar / 3.6 to 5.6 in. w.c., Silver***
- 13 to 24 mbar / 5.2 to 9.6 in. w.c., Red***
- 22 to 39 mbar / 8.8 to 15.7 in. w.c., Black Stripe***
- 32 to 50 mbar / 12.8 to 20.1 in. w.c., Purple***
- 42 to 70 mbar / 16.9 to 28.1 in. w.c., White Stripe***
- 61 to 110 mbar / 0.9 to 1.6 psig, Dark Green***

Type CSB700F/CSB704F

- 13 to 24 mbar / 5.2 to 9.6 in. w.c., Red***
- 22 to 39 mbar / 8.8 to 15.7 in. w.c., Black Stripe***

Type CSB720/CSB724

- 61 to 110 mbar / 0.9 to 1.6 psig, Dark Green***
- 105 to 220 mbar / 1.5 to 3.2 psig, Blue***
- 210 to 380 mbar / 3.1 to 5.5 psig, Black***
- 320 to 570 bar / 4.6 to 8.3 psig, Red with White Stripe***
- 510 to 780 bar / 7.40 to 11.3 psig, Blue with White Stripe***

Type CSB720F/CSB724F

- 270 to 325 mbar / 3.9 to 4.7 psig, Black with White Stripe

Type CSB750/CSB754

- 0.7 to 1.19 bar / 10.2 to 17.3 psig, Purple Stripe***
- 1.05 to 2.7 bar / 15.2 to 39.2 psig, Brown***
- 2.3 to 3.25 bar / 33.4 to 47.1 psig, Grey with Red Stripe***
- 3.1 to 4 bar / 45 to 58 psig, Grey with Orange Stripe***

- continued -

CSB700 Series

Ordering Guide (continued)

Body Orientation⁽¹⁾ (See Figure 5, Select One)

- Position 1***
- Position 2***
- Position 3 (standard)***
- Position 4***

Vent Orientation⁽²⁾ (See Figure 5, Select One)

- Position C***
- Position D***
- Position E***
- Position F (standard)***

Slam-Shut Trip Pressure Setting

(Select One if applicable)

- Overpressure (OPSO) trip only
Indicate Overpressure Trip Point _____
- Over and Underpressure (OPSO/UPSO) trip
Indicate Overpressure Trip Point _____
Indicate Underpressure Trip Point _____

1. For the Type CSB704, choose the body orientation of the primary regulator only. The slam-shut spring barrel will be oriented in the same direction as the primary regulator spring barrel.
2. For the Type CSB704, choose the vent orientation of the primary regulator only. The slam-shut vent will be oriented to point in the same direction as the primary regulator.

Regulators Quick Order Guide

***	Readily Available for Shipment
**	Allow Additional Time for Shipment
*	Special Order, Constructed from Non-Stocked Parts. Consult Your local Sales Office for Availability.
Availability of the product being ordered is determined by the component with the longest shipping time for the requested construction.	

Specification Worksheet

Application:

Specific Use _____

Line Size _____

Gas Type and Specific Gravity _____

Gas Temperature _____

Does the Application Require Overpressure Protection?

- Yes No If yes, which is preferred:
 Relief Valve Monitor Regulator Shutoff Device

Is overpressure protection equipment selection assistance desired? _____

Pressure:

Maximum Inlet Pressure (P_{1max}) _____

Minimum Inlet Pressure (P_{1min}) _____

Downstream Pressure Setting(s) (P_2) _____

Maximum Flow (Q_{max}) _____

Performance Required:

Accuracy Requirements? _____

Need for Extremely Fast Response? _____

Other Requirements: _____

 Webadmin.Regulators@emerson.com

 Facebook.com/EmersonAutomationSolutions

 Fisher.com

 LinkedIn.com/company/emerson-automation-solutions

 Twitter.com/emr_automation

Emerson Automation Solutions

Americas

McKinney, Texas 75070 USA
T +1 800 558 5853
+1 972 548 3574

Asia Pacific

Singapore 128461, Singapore
T +65 6777 8211

Europe

Bologna 40013, Italy
T +39 051 419 0611

Middle East and Africa

Dubai, United Arab Emirates
T +971 4 811 8100

D103484X012 © 2017, 2018 Emerson Process Management Regulator Technologies, Inc. All rights reserved. 05/18.
The Emerson logo is a trademark and service mark of Emerson Electric Co. All other marks are the property of their prospective owners. Fisher™ is a mark owned by Fisher Controls International LLC, a business of Emerson Automation Solutions.

The contents of this publication are presented for information purposes only, and while effort has been made to ensure their accuracy, they are not to be construed as warranties or guarantees, express or implied, regarding the products or services described herein or their use or applicability. All sales are governed by our terms and conditions, which are available on request. We reserve the right to modify or improve the designs or specifications of our products at any time without notice.

Emerson Process Management Regulator Technologies, Inc does not assume responsibility for the selection, use or maintenance of any product. Responsibility for proper selection, use and maintenance of any Emerson Process Management Regulator Technologies, Inc. product remains solely with the purchaser.



The distinctive swirl pattern cast into every actuator casing uniquely identifies the regulator as part of the Fisher™ brand Commercial Service Regulator family and assures you of the highest-quality engineering, performance, and support traditionally associated with Fisher™ and Tartarini™ regulators. Visit www.fishercommercialservice.com to access interactive applications.

